

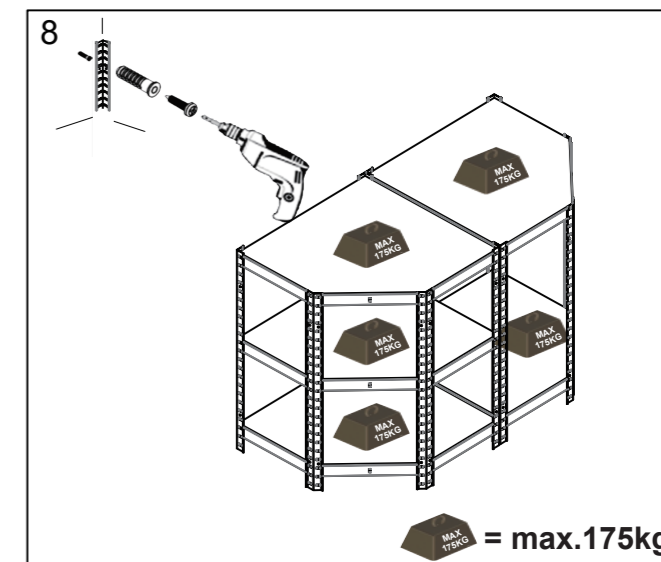

Fare for klemning, skarpe kanter, brug handsker for at undgå skader
 Klämrisk, vassa kanter, använd handskar för att undvika skador
 Puristumisvaara, terävät reunat, käytä käsineitä vammojen välttämiseksi
 Muljumisoht, teravad servad, vigastuste vältimiseks kandke kindaid
 Nebezpečí rozdrčení, ostré hrany, používejte rukavice, aby nedošlo ke zranění
 Opasnost od prignječenja, oštri robovi, nosite rukavice kako biste izbjegli ozljede
 Nevarnost zmečkanin, oštri robovi, nosite rokavice, da preprečite poškodbe

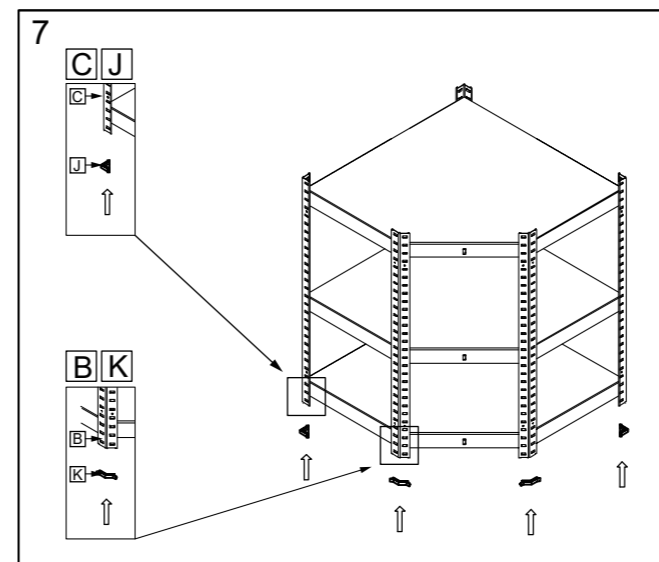

REGALUX

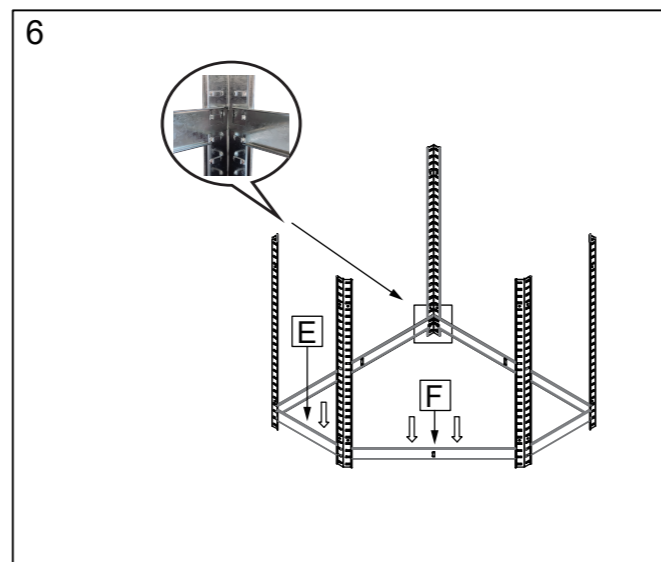
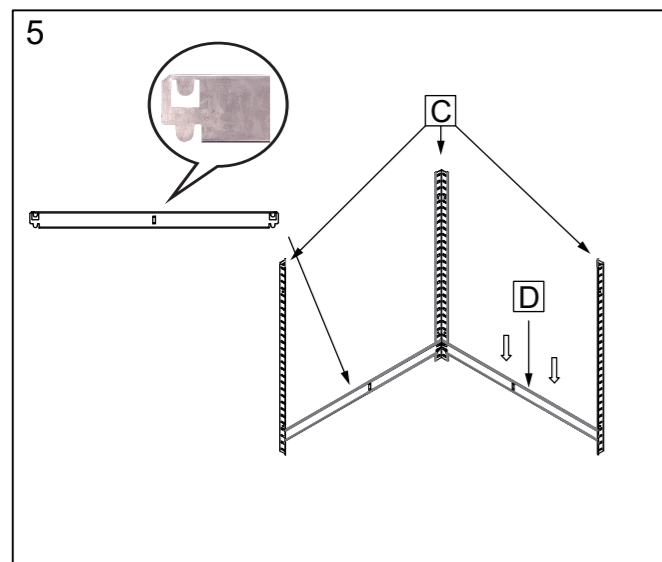
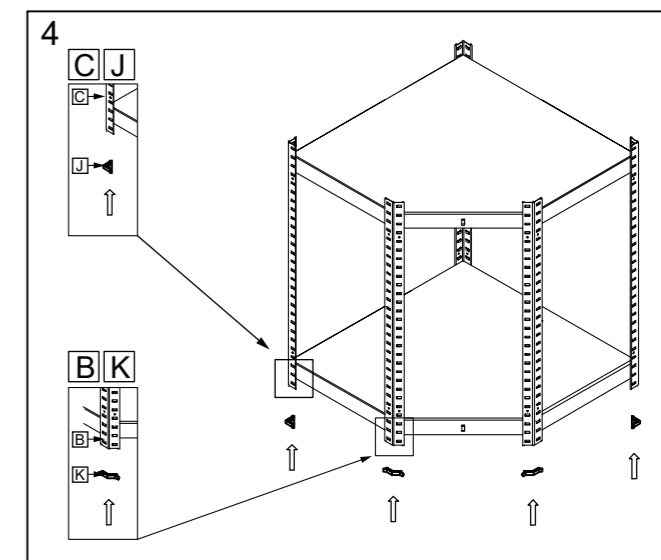
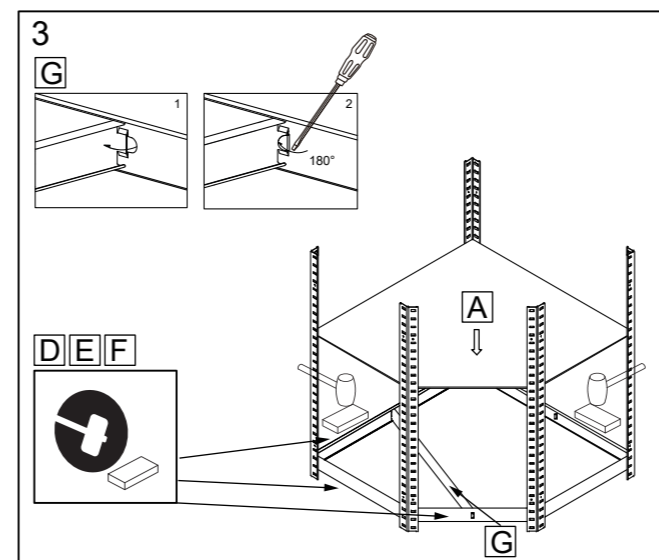
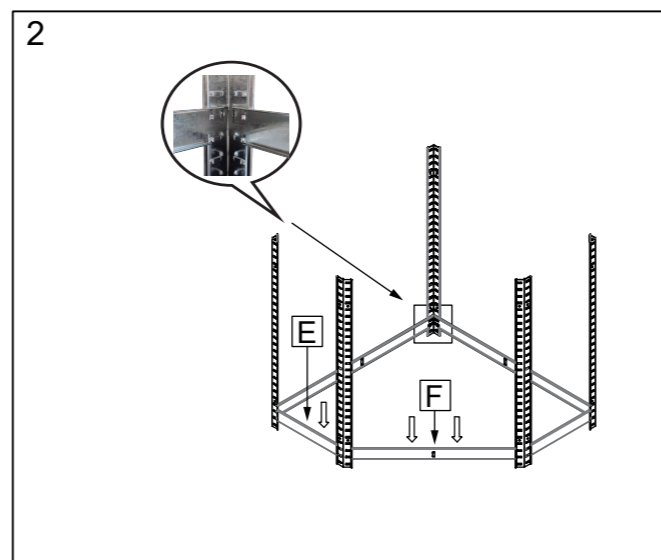
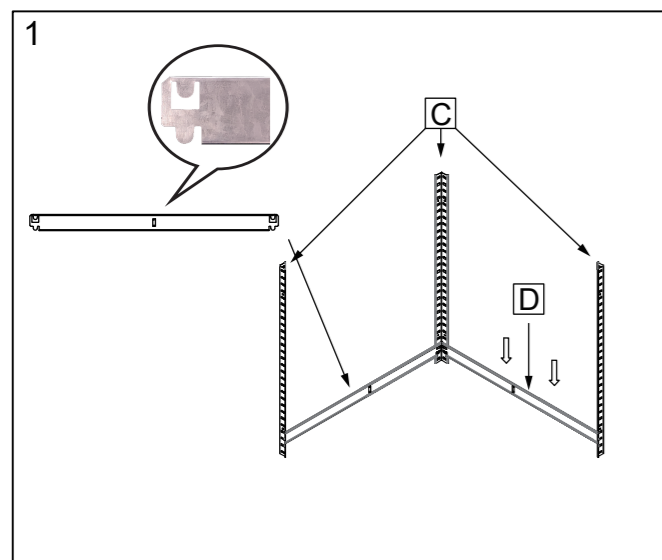
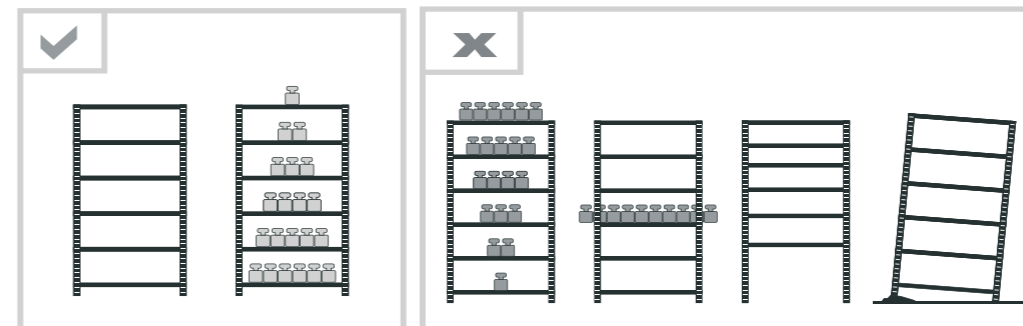
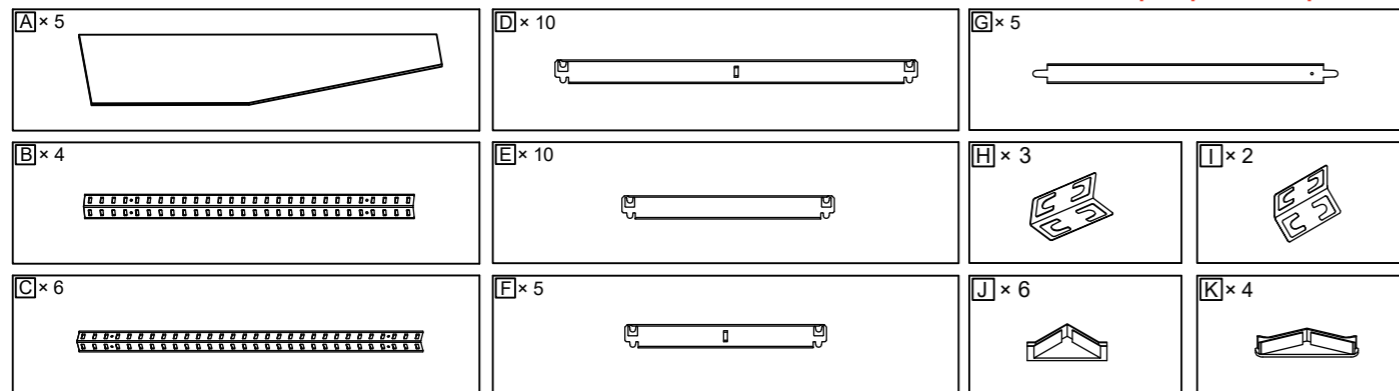
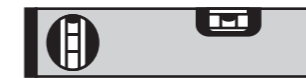

Quetschgefahr, scharfe Kanten, Handschuhe tragen zur Vermeidung von Verletzungen
 Danger of bruising, sharp edges, wear gloves to avoid injuries
 Risque d'écrasement, bords tranchants, porter des gants pour éviter les blessures
 Peligro de aplastamiento, bordes afilados, usar guantes para evitar lesiones
 Pericolo di schiacciamento, bordi taglienti, indossare guanti per evitare lesioni
 Gevaar voor beknelling, scherpe randen, draag handschoenen om verwondingen te voorkomen



Nicht enthalten; not included; non inclus; non incluso; non incluso; niet inbegrepen; ikke inkludert; ingår ej; ei sisälly; ei sisälly; neni v ceně; nije uključeno; ni vključen

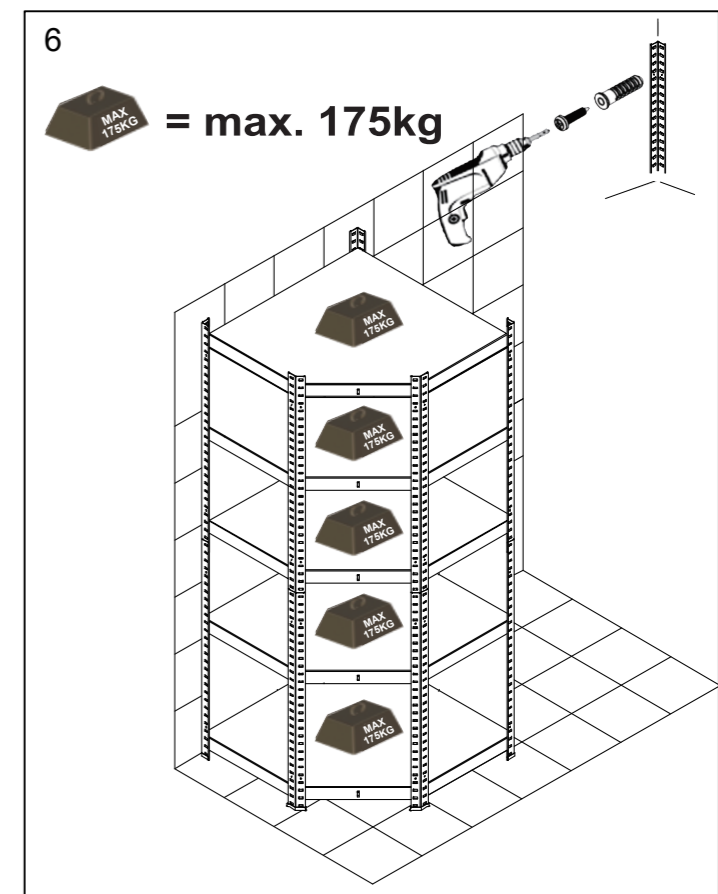
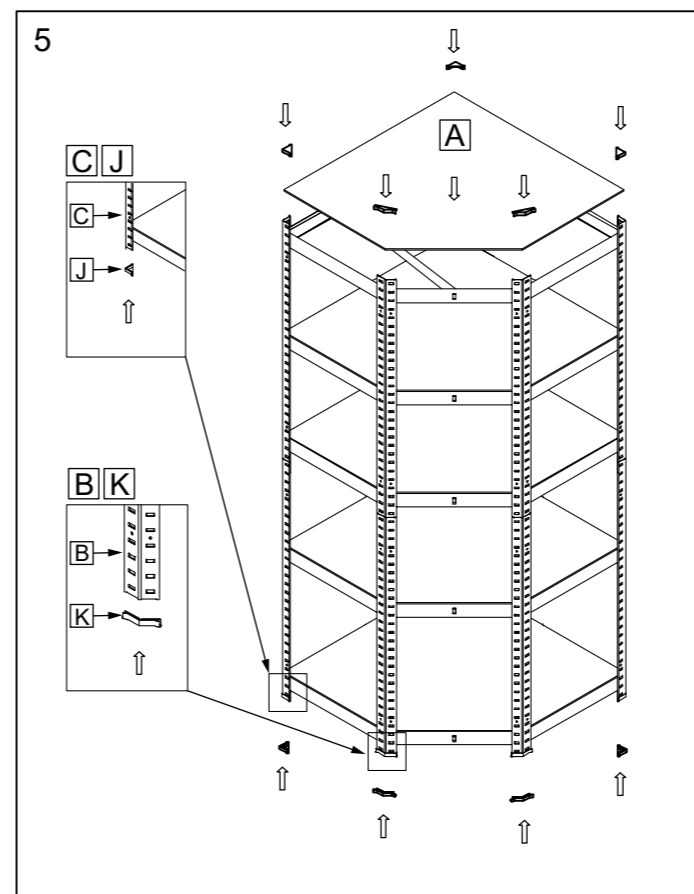
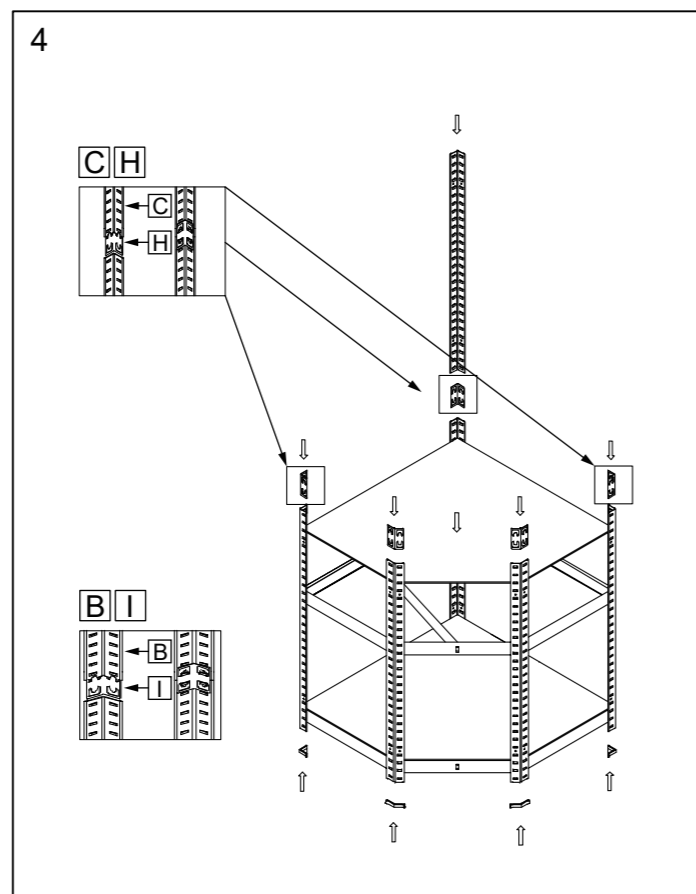
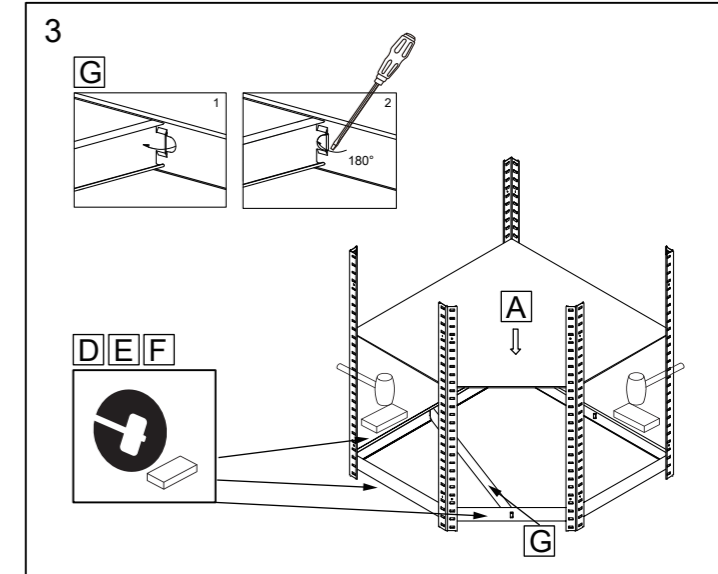
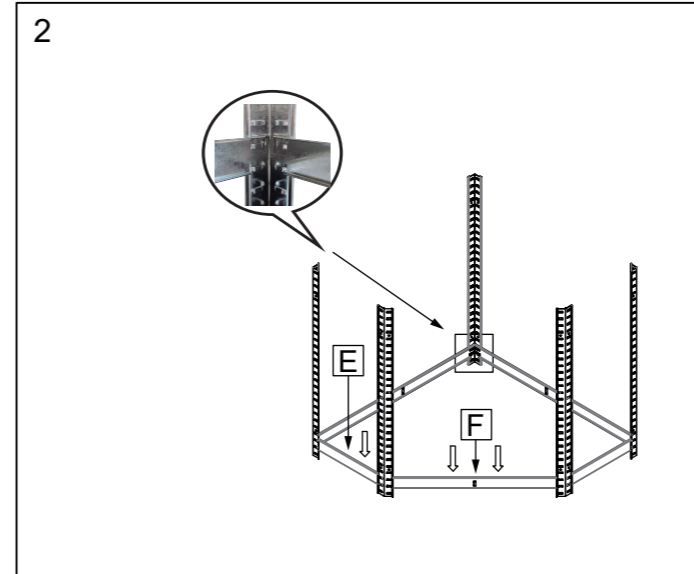
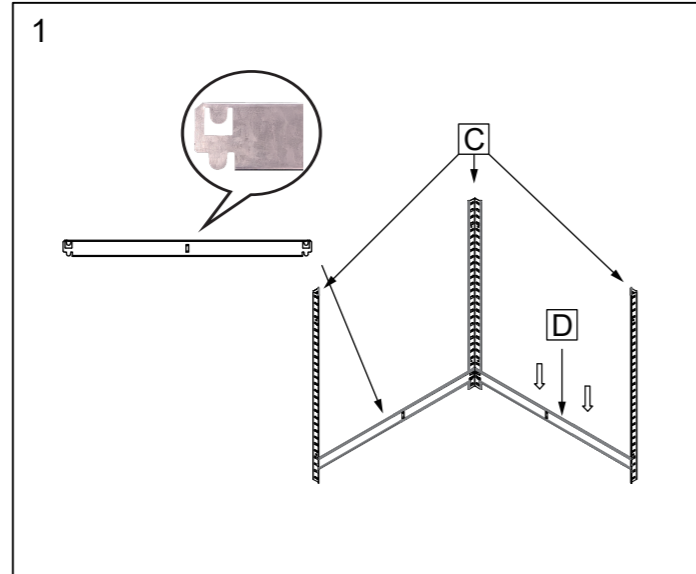
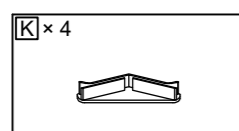
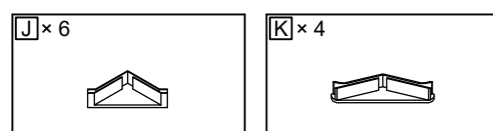
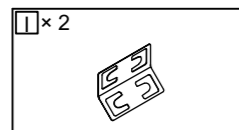
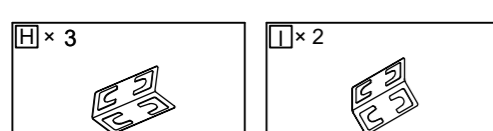
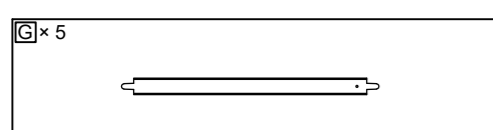
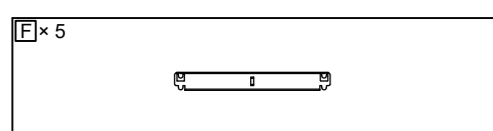
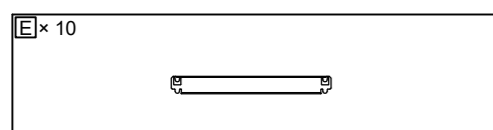
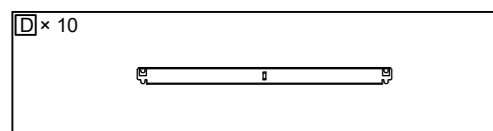
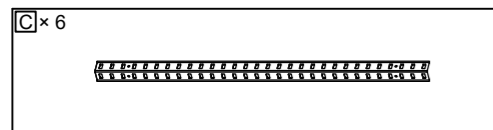
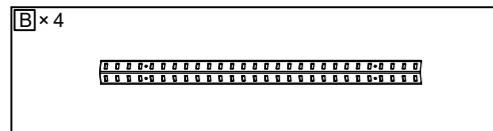

REGALUX®