

Installation/ Assembly and Maintenance Instructions for FLAT flat rainwater tank

FLAT S

1.500 L	Order no. 295120
3.000 L	Order no. 295121
4.500 L	Order no. 295122
6.000 L	Order no. 295123
7.500 L	Order no. 295124
9.000 L	Order no. 295125

FLAT M

3.000 L	Order no. 295115
6.000 L	Order no. 295116
9.000 L	Order no. 295117
12.000 L	Order no. 295118

FLAT L

5.000 L	Order no. 295126
10.000 L	Order no. 295127
15.000 L	Order no. 295128
20.000 L	Order no. 295129



It is essential that you observe the points described in these instructions. Failure to do so will invalidate all warranty claims. For all accessory articles ordered from 4rain, separate installation instructions are provided in the transport packaging.

Should any instructions be missing please request these from us without delay.

It is essential that you inspect the tanks for possible damage before installation.

You can download missing instructions from www.4rain.eu or request these from GRAF.

Contents

1. GENERAL NOTES	2
1.1 Safety	2
1.2 Labelling obligation	2
2. INSTALLATION CONDITIONS	3
3.1 FLAT S	4
3.2 FLAT M	5
3.3 FLAT L	6
4. TANK CONSTRUCTION	7
4.1 Tank components	7
4.2 Internal support pipes S/ M	7
4.3 Internal support pipes L	7
5. INSTALLATION AND ASSEMBLY	8
5.1 Subsoil	8
5.2 Installation pit	8
5.3 Setting in and back-filling	10
5.4 Laying the connecting pipelines	11
6. INSTALLING THE SHAFT EXTENSION AND COVERING	11
7. INSPECTION AND MAINTENANCE	12

1. General Notes

1.1 Safety

Observe the relevant accident prevention regulations of the trade associations according to BGV C22 during all work. Particularly for inspecting the tanks a second person is required for safety reasons.

Furthermore, observe the relevant regulations in respect of installation, assembly, repair, maintenance, etc. You will find relevant information in the respective sections of these instructions.

During all work on the system or parts thereof always shut down the entire system and secure it against unauthorised re-starting.

Always keep the tank cover closed except when working in the tank. Otherwise there is a high risk of accident.

4rain offers an extensive assortment of accessory parts which are all matched to each other and which can be extended to complete systems. The use of other accessory parts can impair the functional reliability of the system and invalidate the warranty for any resulting damage.

1.2 Labelling obligation

Label all pipelines and tapping positions for service water with the words "Non-potable water" in writing or in symbols (DIN 1988, Part 2, Section 3.3.2) in order to prevent inadvertent connection to the drinking water supply system even after many years. Mix ups, e.g. by children may still occur even in the case of correct identification. All service water extraction points must therefore be installed with valves with **Child proof locks**.

2. Installation Conditions

Coverage heights with shaft extension in the green zone.

The maximum earth coverage from tank shoulder "A" results from the maximum length of the original shaft extension and is 780 mm maximum.

This may not be further lengthened, but can be shortened to 400 mm minimum if required.

The earth coverage over tank cover "B" is 200 mm

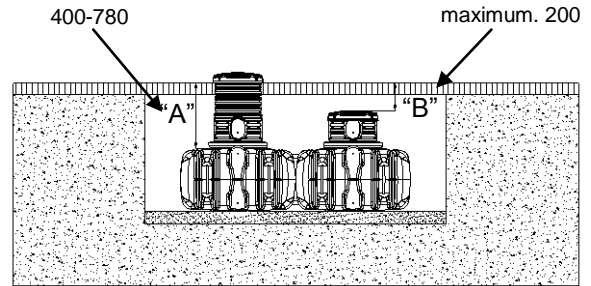

The tanks may not be installed in areas used by passenger cars.

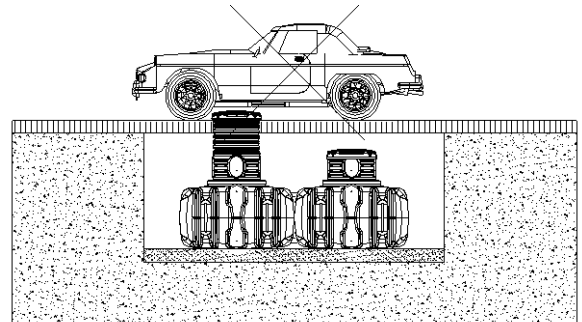

The tanks may not be installed in the groundwater/artesian water. Even if it is expected that groundwater/artesian water occurs only occasionally, this must be led off by a drainage facility.

As the occurrence of groundwater/artesian water can be excluded only with difficulty, we recommend the installation of a drainage line as a general rule.

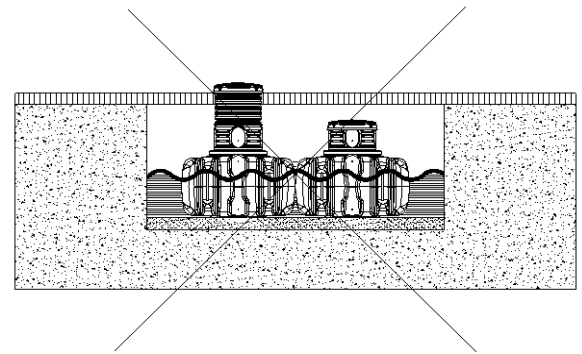

3. Technical Data

3.1 FLAT S

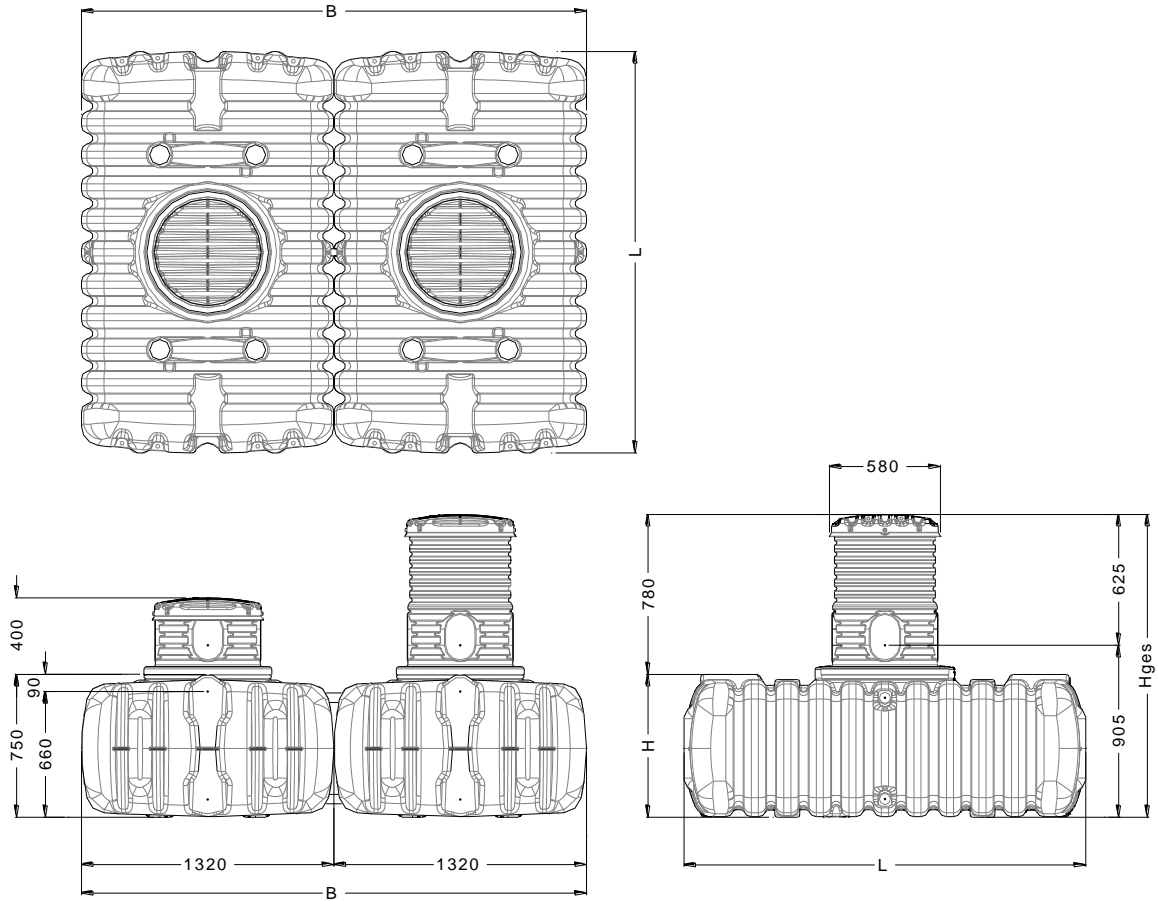

Tank	1,500 L	3,000 L*	4,500 L*	6,000 L*	7,500 L*	9,000 L*
Order no.	295120	295121	295122	295123	295124	295125
Weight	approx. 80 kg	approx. 160 kg	approx. 240 kg	approx. 320 kg	approx. 400 kg	approx. 480 kg
L (L)	2100 mm	2100 mm	2100 mm	2100 mm	2100 mm	2100 mm
W (B)	1320 mm	2640 mm	3960 mm	5280 mm	6600 mm	7920 mm
H (H)	750 mm	750 mm	750 mm	750 mm	750 mm	750 mm
Hoverall (Hges)	1150-1530 mm	1150-1530 mm	1150-1530 mm	1150-1530 mm	1150-1530 mm	1150-1530 mm

*including connection kit(s)

3. Technical Data

3.2 FLAT M

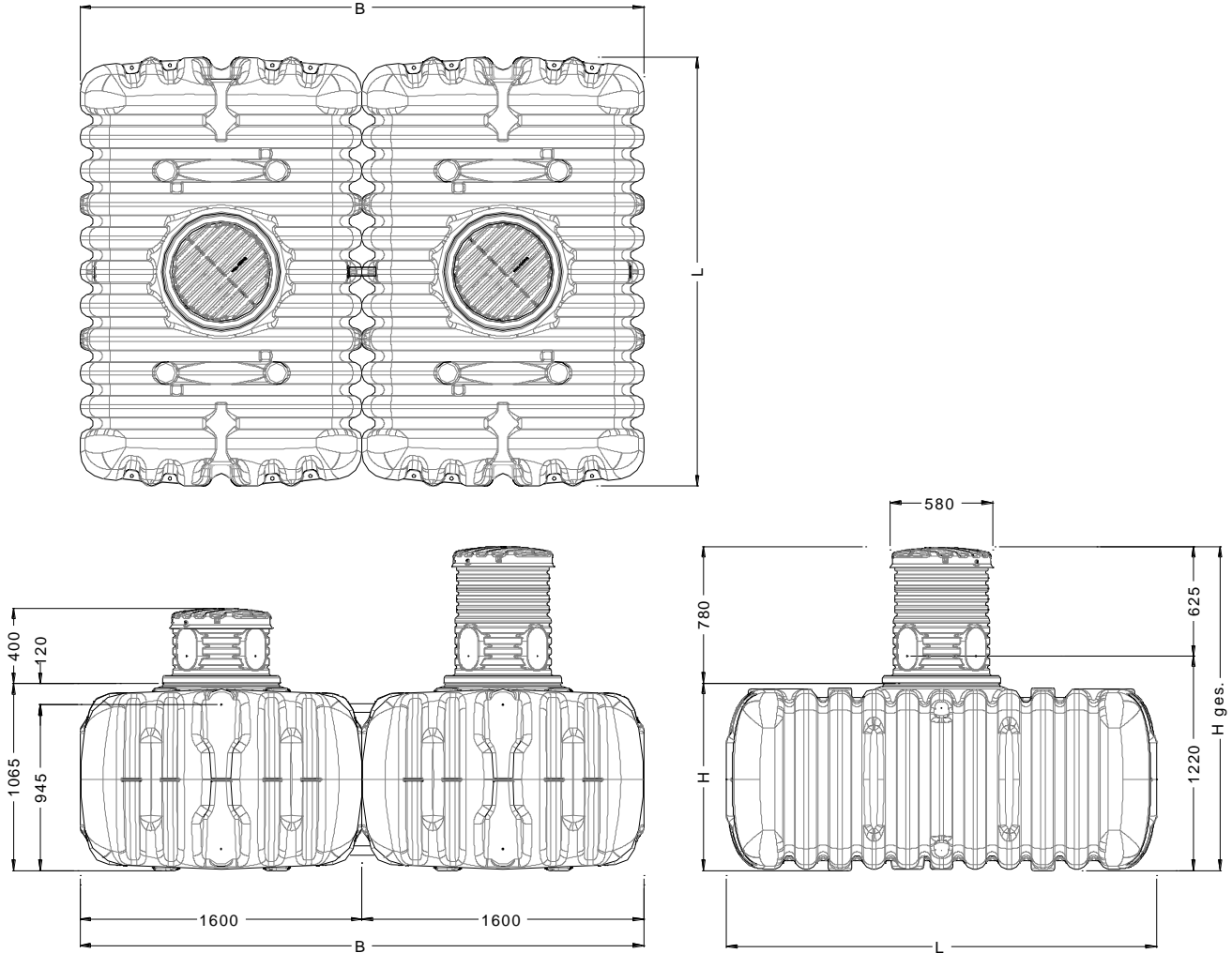

Tank	3,000 L	6,000 L*	9,000 L*	12,000 L*
Order no.	295115	295116	295117	295118
Weight	approx. 115 kg	approx. 230 kg	approx. 345 kg	approx. 460 kg
L (L)	2445 mm	2445 mm	2445 mm	2445 mm
W (B)	1600 mm	3200 mm	4800 mm	6400 mm
H (H)	1065 mm	1065 mm	1065 mm	1065 mm
Hoverall (Hges)	1465–1845 mm	1465–1845 mm	1465–1845 mm	1465–1845 mm

*including connection kit(s)

3. Technical Data

3.3 FLAT L

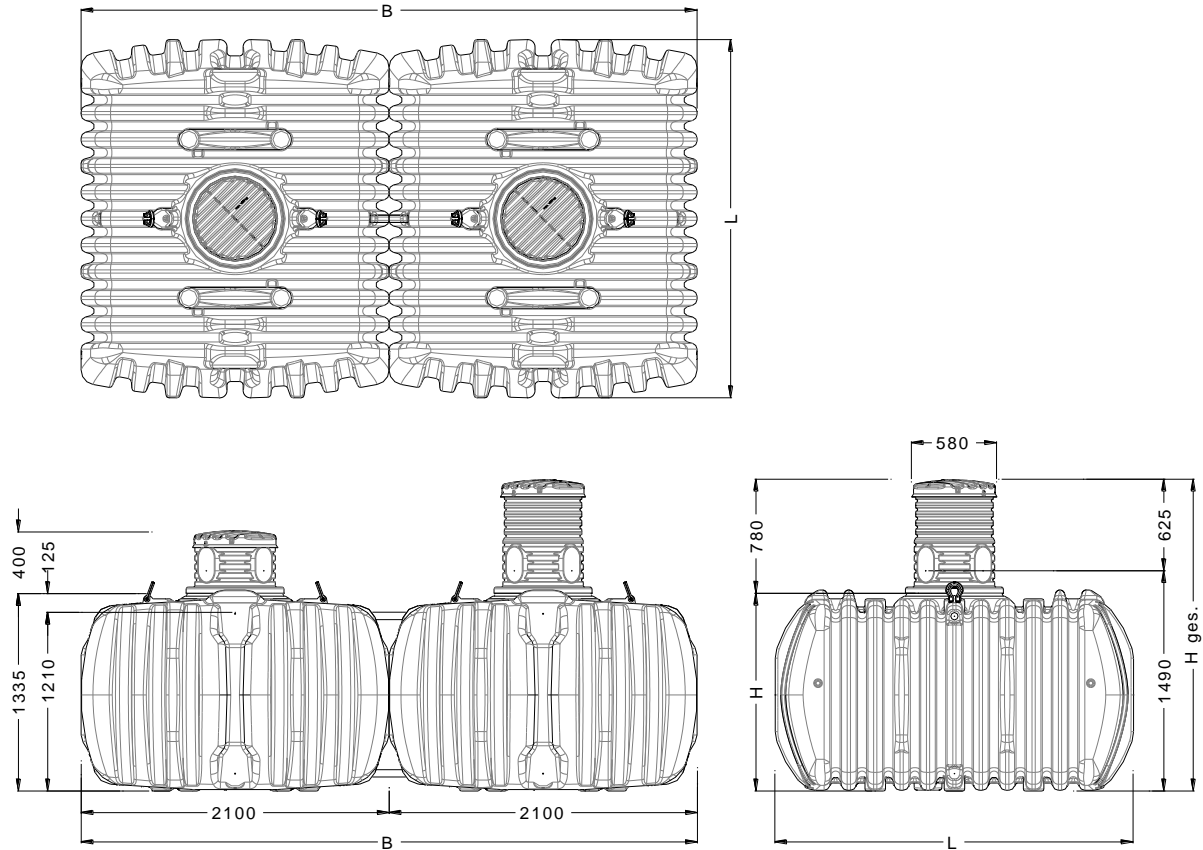

Tank	5,000 L	10,000 L*	15,000 L*	20,000 L*
Order no.	295126	295127	295128	295129
Weight	approx. 240 kg	approx. 480 kg	approx. 720 kg	approx. 960 kg
L (L)	2445 mm	2445 mm	2445 mm	2445 mm
W (B)	2100 mm	4200 mm	6300 mm	8400 mm
H (H)	1335 mm	1335 mm	1335 mm	1335 mm
Hoverall (Hges)	1735–2115 mm	1735–2115 mm	1735–2115 mm	1735–2115 mm

*including connection kit(s)

4. Tank Construction

4.1 Tank components

① Cover	
② Shaft extension	
③ Seal	
④ FLAT flat tank	
⑤ DN 50 connection kit	

4.2 Internal support pipes S/ M

① Sectional view of support pipe	② Overview of support pipe locations
→ Control for proper seating before installing!	

4.3 Internal support pipes L

① Sectional view of support pipe	② Overview of support pipe locations
→ Control for proper seating before installing!	

5. Installation and Assembly

① Ground earth	⑤ Enclosure (round pebble stones max. grain size 8/16 mm)
② Cover	⑥ FLAT flat tank
③ Shaft extension	⑦ Compacted sub-structure
④ Outer layer	$\beta \rightarrow$ DIN 4124 from 1250 mm pit depth

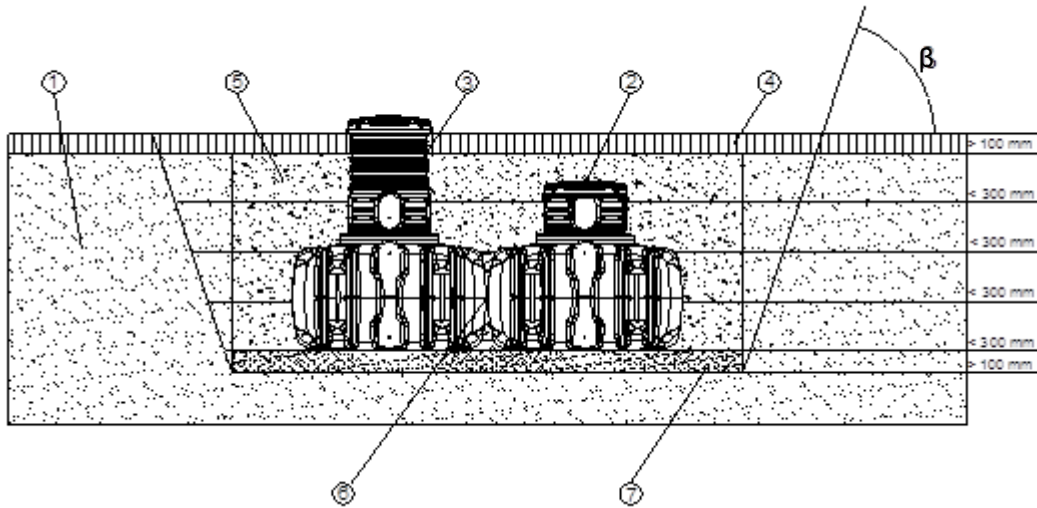

5. Installation and Assembly

5.1 Subsoil

The following points must be clarified before installation:

- The suitability of the soil for installation in accordance with DIN 18196
- The maximum groundwater levels and the seepage capability of the subsoil

For the determination of the soil physical properties an expert soil evaluation should be requested from the local public construction authority.

5.2 Installation pit

In order to ensure that sufficient working space is available the ground area of the installation pit must extend beyond the dimensions of the tank by > 100 mm on each side and the distance from fixed structures must be at least 1000 mm.

From a pit depth of > 1250 mm a slope must be constructed in accordance with DIN 4124. The subsoil must be flat and have sufficient load-carrying capacity.

The depth of the pit must be dimensioned so that the maximum earth coverage (780 mm above the tank shoulder) is not exceeded. When the system is in use throughout the entire year the tank and the system parts bearing water must be installed in a frost-free area. As a rule the frost-free depth is around 600 mm. The responsible authority can provide more exact information about this depth.

A layer of compacted **round pebble stones (max. grain size 8/16 mm)** (thickness 100 - 150 mm) is deposited on top.

5. Installation and Assembly

5.2.1 Location on a slope, embankment, etc.

The installation of the tank in the immediate vicinity (< 5 m) of a slope, earth mound or embankment (greater than 2 % gradient) requires a statically calculated masonry retaining wall to take up the soil pressure. The retaining wall must extend beyond the tank dimensions by at least 500 mm in all directions and be a minimum of 1000 mm away from the tank.

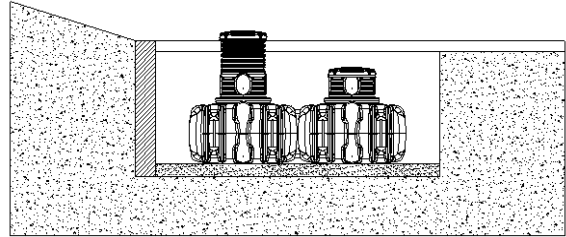

5.2.2 Groundwater and cohesive (impermeable to water) soils (e.g. loamy soil)

The tanks may not be installed in groundwater/ artesian water. Even if it is expected that groundwater/ artesian water occurs only occasionally, this must be led off by a drainage facility.

The drainage line may have to end in a vertically constructed DN 300 pipe in which a submersible pressure pump is installed to pump out excess water. The pump must be regularly controlled.

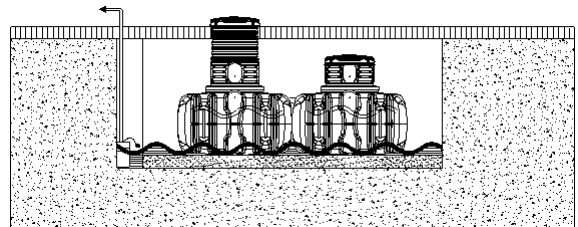

5.2.3 Installation next to trafficways

If the underground tanks are installed next to trafficways the minimum distance from these must be at least the depth of the installation pit (H).

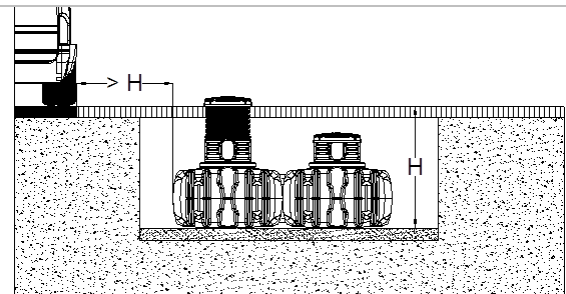

5.2.4 Connection of several tanks

Several tanks can be connected with a connection kit and DN 50 HT pipe sections. The connection kit is comprised of four special DN 50 seals and four DN 50 HT pipe sections, together with lubricant.

The individual tanks are connected to each other at the top and bottom at the drilling position provided (see figure). The openings for the connections are drilled with a 50 mm diameter core drill. The special DN 50 seals are inserted in the openings. In order to simplify inserting the pipes into the seals the seal and the end of the pipe section must be greased with the lubricant.

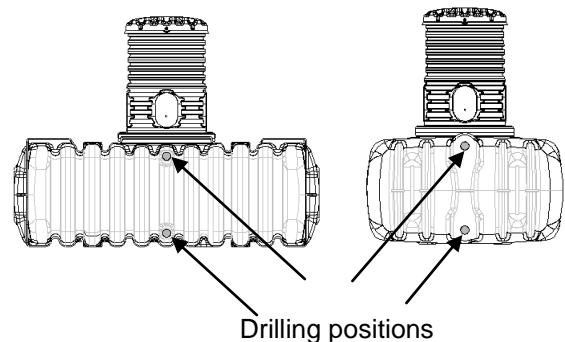

The tanks can be connected to each other with the

longitudinal or the transverse sides in the installation pit

The spacings between the tanks must be L: min. 100 mm, Q: min. 0 mm. The individual spaces in between must be well sealed with a hand rammer.

The connecting pipe sections may not be shortened and must extend at least 100 mm into the tank.

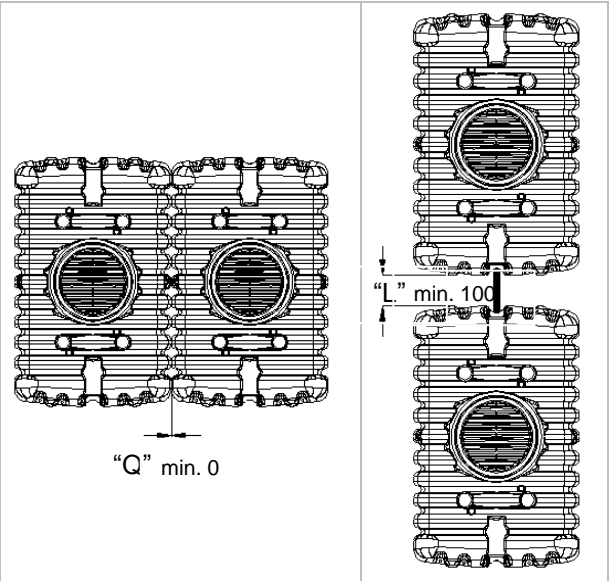

5.3 Setting in and back-filling

Set the tanks with suitable equipment without bumping into the prepared installation pit.

In order to prevent deformations fill the tanks one-third full with water before filling in the installation pit (control sealing). Then fill in with round pebble stones (max. grain size 8/16 mm) in layers of max. 300 mm up to the upper edge of the tank and compact. The several layers must be compacted by means of a hand rammer.

Especially in the lower area as well as between the tanks (split maximum grain size 2/5 mm). Avoid damage to the tank while sealing. Never use mechanical compacting machines. The enclosure must be at least 100 mm wide.

Notice: Please ensure a good compaction of the filling material. Especially in the area of the joints and cavities between the several tanks (see fig.).

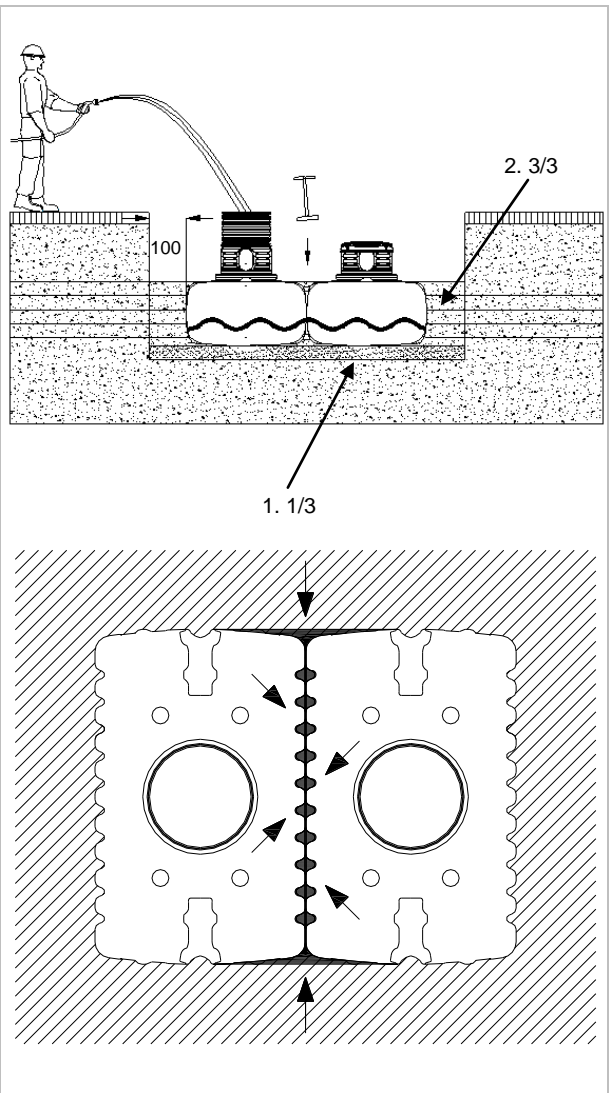

5. Installation and Assembly

5.4 Laying the connecting pipelines

All supply lines and overflow lines must have a gradient of at least 1 % in the flow direction (possible down-line settling must be considered).

Prior to completion of the backfilling verify that the pre-installed overflow bend inside the tank is pointing upwards.

If the tank overflow is connected to a public canal this must be secured against backpressure in accordance with DIN 1986 by means of a pump station (combined sewer) or a backflow stopper (pure rain-water canal).

All intake, pressure and control lines must be led through an empty conduit installed with a slope towards the tank, without sagging and as well as possible along a straight line. Pipe elbows required must be with 30° fittings.

Important: Connect the empty conduit to an opening **above** the maximum water level.

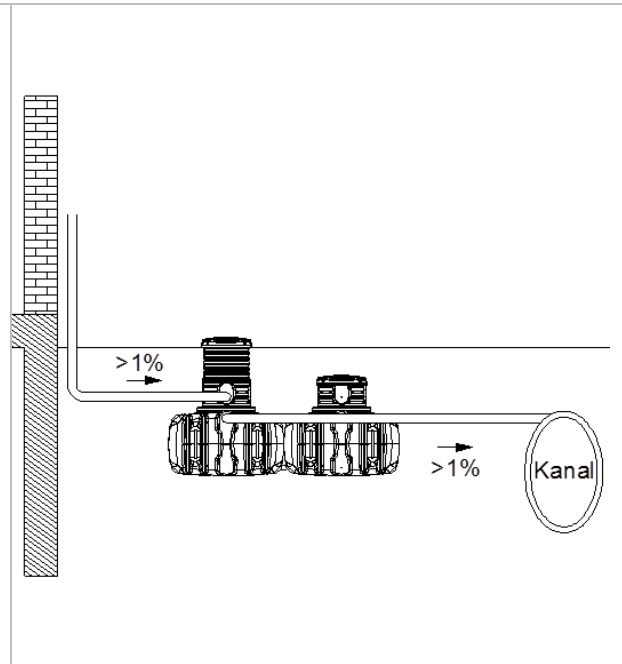

6. Installing the Shaft Extension and Covering

① Cover	
② Shaft extension	
③ Seal	
④ FLAT flat tank	

The shaft extension can be shortened at the grooves. This allows earth coverage from 400 to 780 mm above the tank shoulder.

To mount the shaft extension ② set the extension loosely onto the tank opening ④ and then mount the seal supplied ③. It is not necessary to attach the extension, as the shaft is held in position by the surrounding soil after filling in the installation pit.

Then set on the cover ① and close off with child protection. **Tighten the screw connections on the cover firmly enough so that a child cannot open them!**

7. Inspection and Maintenance

Inspect the entire system at least every three months for sealing, cleanliness and stability.

Maintenance of the entire system is required in intervals of around five years. This includes cleaning all system components and controlling their function. Proceed as follows with maintenance:

- Completely empty the tank.
- Control all built-in parts for firm seating.



4rain - a trademark of the Otto Graf GmbH