

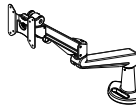







Elevate Monitor Arm⁵⁰

PARTS AND TOOLS

(A)	x1 PCE	
(B)	x1 PCE	
(C)	x4 PCS M4x10	
(D)	x1 PCE	
(E)	x1 PCE 6mm	
(F)	x1 PCE 5mm	
(G)	x1 PCE 4mm	
(H)	x1 PCE 2mm	

Follow instructions, and if there are steps that are incomprehensible, please let us know and we will get back to you. For assembly, use only prescribed tools.

STEP 1

Use the 2 mm Allen key (H) to loosen the screw that is keeping the arms of the monitor arm (A) in the clamp and remove it as seen in the illustration. Put the arm and hexagon cup point screw aside somewhere close and safe as it will be re-inserted for STEP 3.

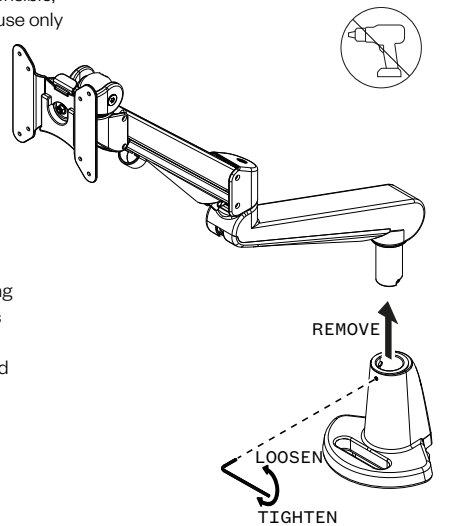

STEP 2

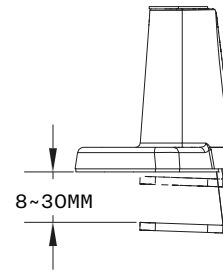

Turn grommet upside down and adhere the Pad (B). Use Allen Key (E) to adjust the height of the clamp so that it fits your table. Tighten until sturdy and ascertain that the clamp can not be moved from its position from the table.

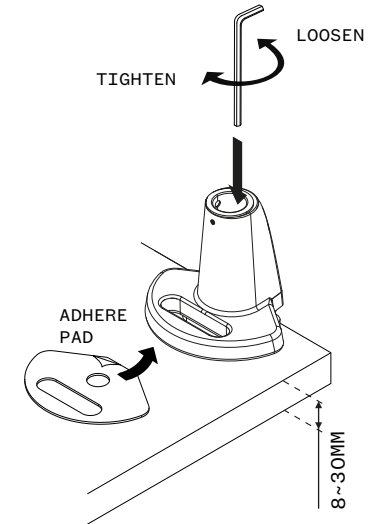

STEP 3

Insert the removed arms into the clamp and fasten the hexagon cup point screw with the Allen key (H) Adjust the tension of the rotation to your need.

To keep the arms completely rigid, fasten the small cup point socket screws as tight as possible while maintaining the intended position.

Optional: Fasten the screw with the Allen key (H) if you desire to limit the rotational movements to 180°.

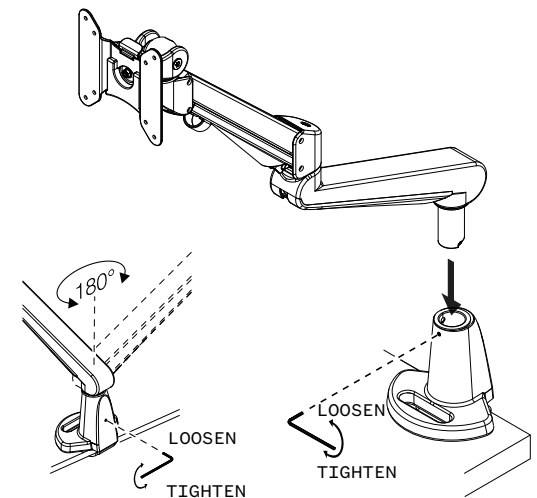

STEP 4

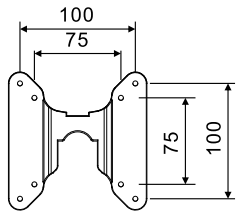

Place monitor face down on a flat surface. Align the VESA plate holes with the holes on the back of the monitor and attach using the screws for the desired monitor.

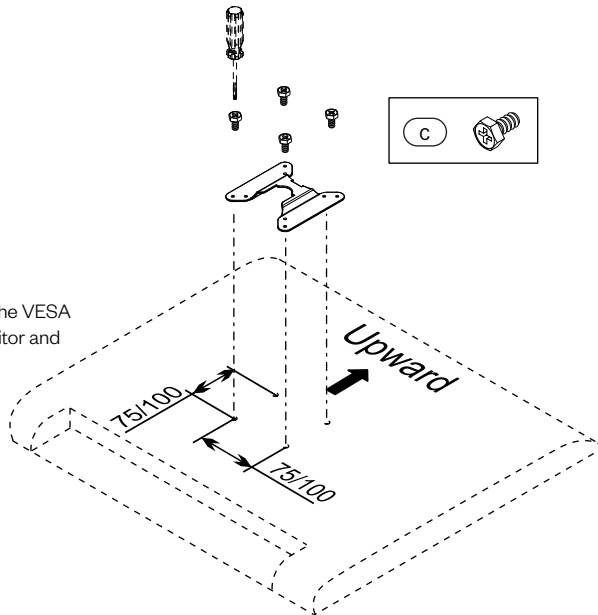

STEP 5

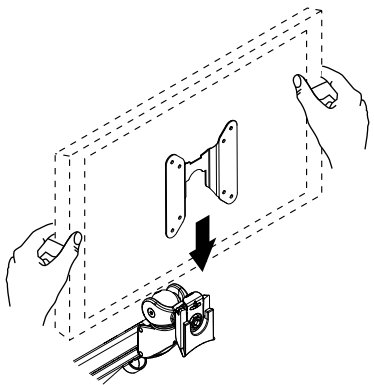

Slide the monitor (with VESA plate) onto the arm and make sure it "clicks" securely into position.

Use screwdriver to secure the screw.

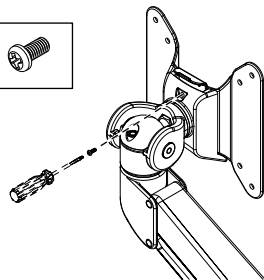

STEP 6

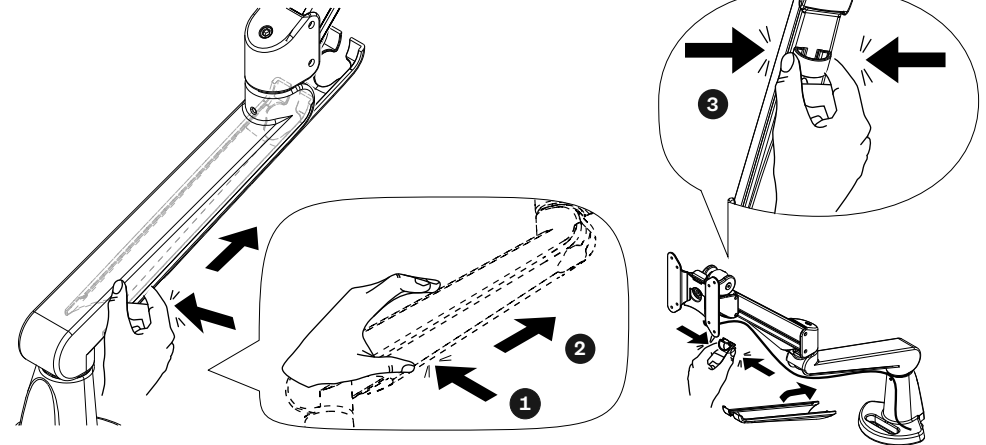

Unattach the cable collector and route the cables through. Once satisfied, re-attach the collector back into place. Proceed by continuing the routing through the cable clip.

TENSION ADJUSTMENT

CAUTION:
Support and hold on to the arm while adjusting the tension.

ADJUSTMENT:
Use the Allen key provided to adjust the tension to correspond to the weight of the desired monitor. Turn the Allen key (F) counter-clockwise to adjust for heavier monitors; clockwise for lighter monitors. Once the adjustment is done, the monitor should be experienced as weightless and the monitor should remain in any position without dropping nor rising.

RECOMMENDATIONS:

- 3-8 kg (6.6-17.6 lbs).
- The products loading capacities are based on monitors' center of gravity less than 3 cm from the end of the VESA interface.
- Loading capacity could be reduced if the monitor size is greater than 26 inches or if the thickness exceeds 5.5 cm.
- All product specifications in catalogues are subject to change without notice.

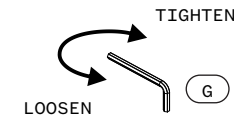

When the joint loosens, use Allen key (G) to tighten the joint. Clockwise to tighten for heavier monitors; Counterclockwise to loosen.

