

**TILE CUTTER WITH SLIDING TABLE**

- Excellent cutting length of 450 mm thanks to the sliding table
- Maximum cutting height of 32 mm
- Powerful 900 Watt motor, 3600 rpm
- Angular stop enables mitre cuts of 0° to +45°, with integrated measurement scale
- Premium-quality 180 mm diamond cutting wheel
- Integrated work bench mount ensures secure positioning
- Low weight of only 11.75 kg and rubberised transport handles allow mobile use
- Practical storage options for longitudinal stop and angular stop as well as additional accessories
- Thanks to the protective cover that can be height-adjusted, materials of different thicknesses can be cut without problems
- Indoor and outdoor use possible

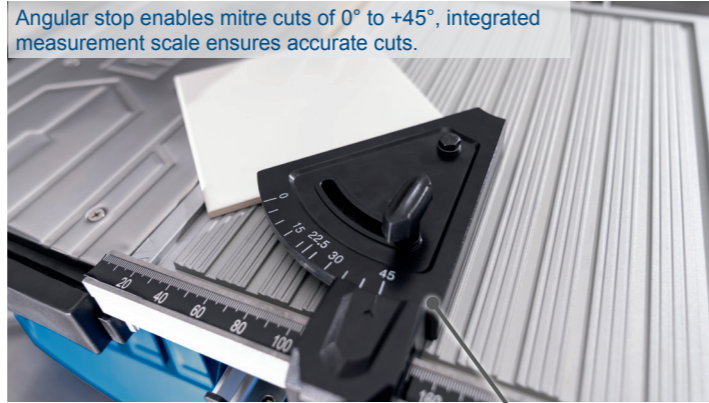

Angular stop enables mitre cuts of 0° to +45°, integrated measurement scale ensures accurate cuts.

Angular stop

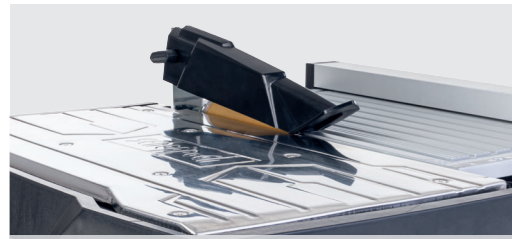

The protective cover can be height-adjusted, different material thicknesses can therefore be cut safely.

180 Ø diamond cutting wheel

Sliding table



Rubberised transport handle

Work bench mount

**SPECIFICATIONS**

|                       |                    |
|-----------------------|--------------------|
| Dimensions L x W x H  | 616 x 494 x 178 mm |
| Table size            | 493 x 270 mm       |
| Diamond cutting wheel | 180 x 25.4 mm      |
| Cutting length        | 450 mm             |
| Cutting height        | 32 mm              |
| Motor                 | 230 V~             |
| Power output          | 900 W              |

**LOGISTICAL DATA**

|                      |                    |
|----------------------|--------------------|
| Weight net / gross   | 11.75 / 14 kg      |
| Packaging dimensions | 640 x 520 x 205 mm |
| Article number       | 5906711901         |
| Barcode              | 4046664194613      |
| 20 Container         | 400 pcs            |
| 40 Container         | 820 pcs            |
| 40 HQ Container      | 977 pcs            |



**EXAMPLES OF USE SUITABLE FOR**

Indoor



Outdoor



Storage options for longitudinal stop and angular stop as well as additional accessories.

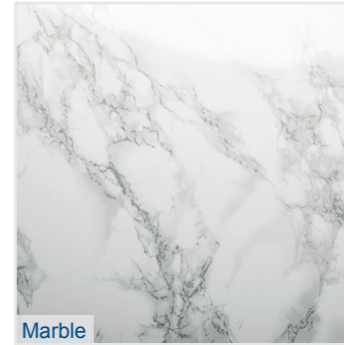

Marble

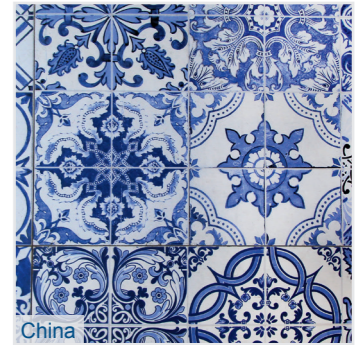

China



Ceramics



Tiles

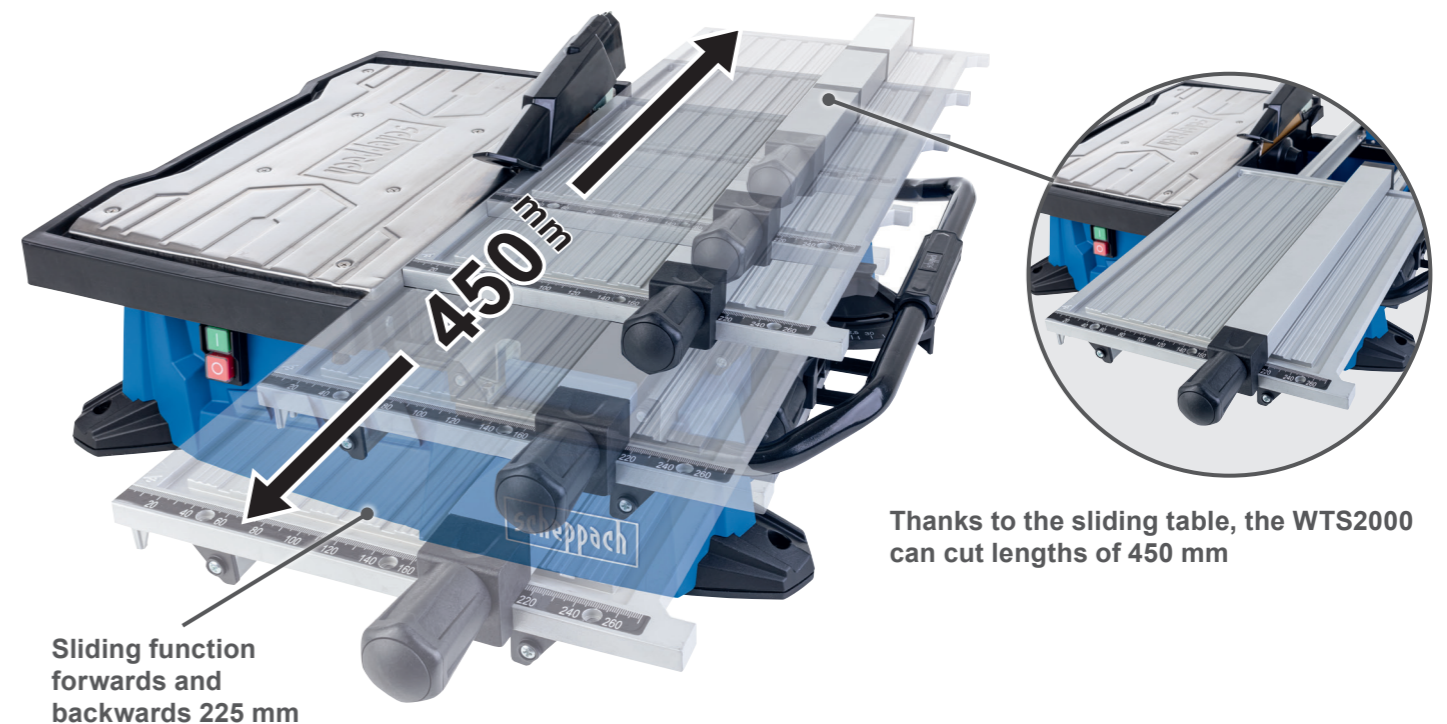

Sliding function forwards and backwards 225 mm

Thanks to the sliding table, the WTS2000 can cut lengths of 450 mm

**PRODUCT DETAILS**

Table size



493 x 270 mm

Cutting length



450 mm

Cutting high



32 mm

Diamond cutting wheel



Ø 180 x 25.4 mm

Power output



900 W

Speed



3600 U/min

Stop rail with scale

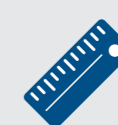

Lightweight & compact

