

Instructions manual

GUSTAV

WI-FI+IR DIGITAL MUSIC LED AMBIENT LIGHT

JP-AL07R

rev 1



Luminans

Product features

- WiFi + IR control
- Voice & smart speaker control
- Timer control
- Music

A complete range of RGB + IC is available
DIY seven color changes and dimming
Remote control after internet connection

Parameters

Model No.	Color	Input voltage
JP-AL07R	RGB	DC5V

Product dimension

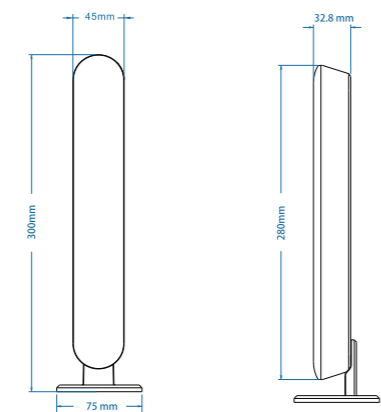

Wiring diagram

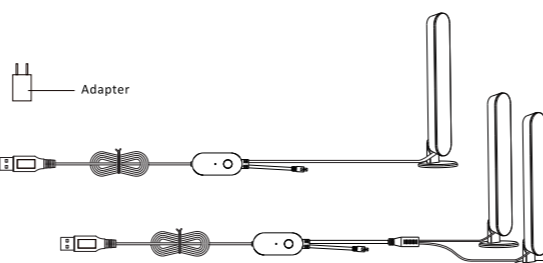

Install through the base bracket

- Align the hole on the mounting base with the screw hole at the bottom of the lamp housing, and adjust the bracket to a linear position.
- Insert the screw into the mounting hole and tighten the screw with a Allen key.
- Check that the underside of the lamp housing closes with the mounting surface on the bracket.

If it's closemounting surface, adjust the direction of the bracket.

- After the lamp body has been locked to the base, the angle of rotation can not be to the left or right.

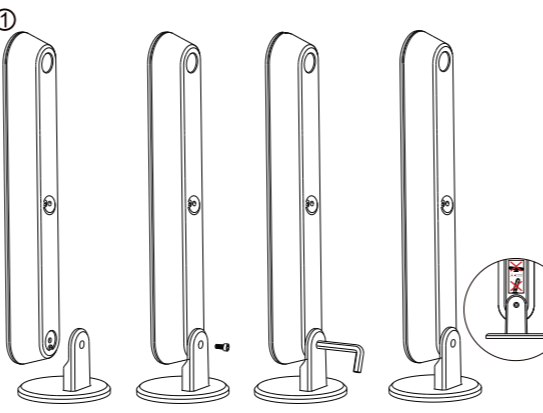
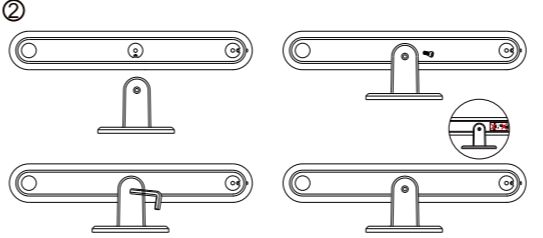

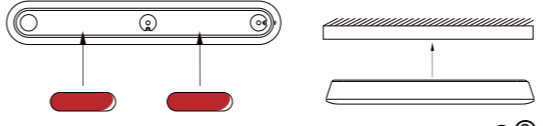

The appearance of all products is subject to actual conditions and the pictures are for reference only.

- Tear off the adhesive paper and attach it to the back of the lower shell, there are 2 places in total.
- Wipe the surface to be attached, then tear off the other side the centrifugal paper and paste on.

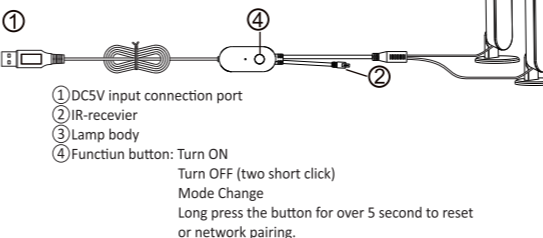

Product function diagram



- DCSV input connection port
- IR-receiver
- Lamp body
- Function button: Turn ON (Turn OFF (two short click) Mode Change Long press the button for over 5 second to reset or network pairing.

Attentions

- Use DCSV Power supply. Power on the lamps. (In order to ensure the lamp works properly).
- Install the WiFi-controller correctly. Use 3M tape to fix it.
- Application device: Certified power adapter with USB2.0 (with output current over 1A) or USB3.0.

Download APP

- Search the APP- "TUYA SMART" from Apple Store or Google Play.
- Scan the QR code from the label or user manual

App supports Android 5.0 and IOS 10.0 or later.



Android 5.0 iOS 10.0

Log in/Register an account

Open the "Tuya Smart" Register for a new account or log in with your existing account

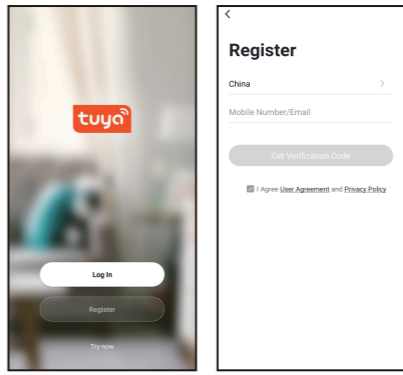

App connection

- Turn on the LED light and go into "home" in the app. Make sure your mobile is connected to the same WiFi network.
- Connect the device: Description 1) After turning on the power, turning on and off 3 times (or long press the button for more than 5 seconds), the lamp will enter a flashing mode quickly. Press "+" to add devices. If your mobile has already activated Bluetooth before connecting the LED, you do not need to turn it on Bluetooth again, when the app connects to the LED lamp automatically. If your mobile did not turn on Bluetooth before connecting the LED, the app will ask you to turn on Bluetooth. Then select "Allow" and the Bluetooth function on your mobile will be switched on. After that, information about the LED lights will appear, then select "Go to add". Select "+" and go to "Enter Wi-Fi password" Enter the WiFi password and select "Confirm" Select "Done" when "Added Successfully" is displayed. (If Description 1 is not compatible with your devices, see Description 2)

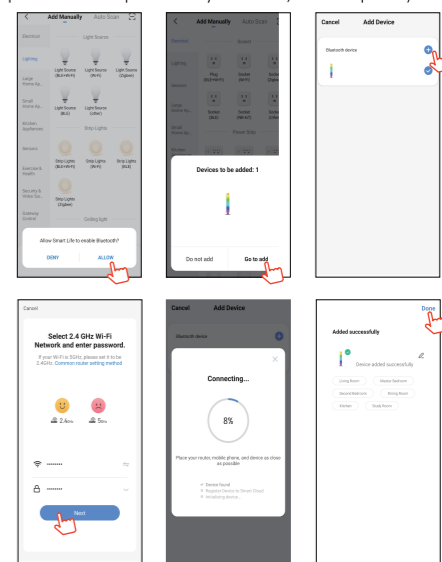

Option 2:

Turn on the power, then press / off 3 times (or hold down the button for over 5 seconds), then Gustav will start flashing. Press "+" Then select "lighting" press "Select 2.4 GHz Wi-Fi Network and enter password" Enter the Wi-Fi password, then select "Next" (make sure your mobile and device are connected to the same Wi-Fi network). Then go to "Scan devices" Select "Next" "Done" to enter the operating modes.

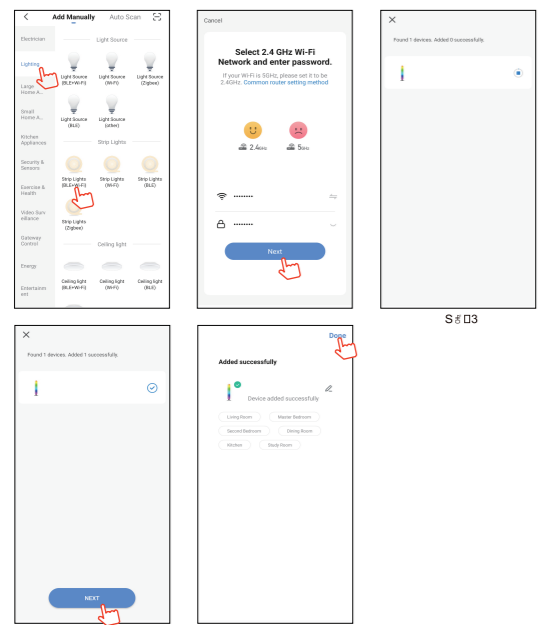

3. When you connect the power, Gustav does not flash. Please press button for more than 5 seconds, until it starts flashing. Go to the App and select "add all devices" Then press "add device"

Interface introduction

1. APP preset scene types include: Quiet, Active and Romantic.

- The quiet scenes include: Film, Dating, sunset and Christmas.
- The active scenes include: Romantic, Colorful, Dynamic and Dream
- The romantic scenes include: Rainbow, Flowing water.

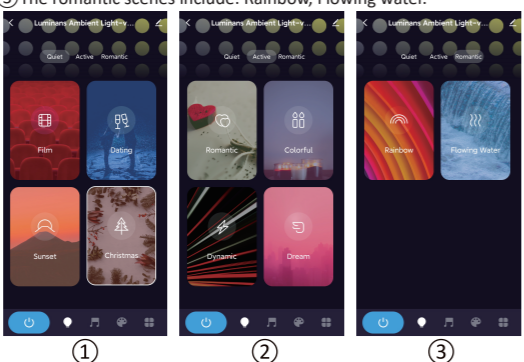

- Rhythm
- Scroll
- Energy
- Spectrum

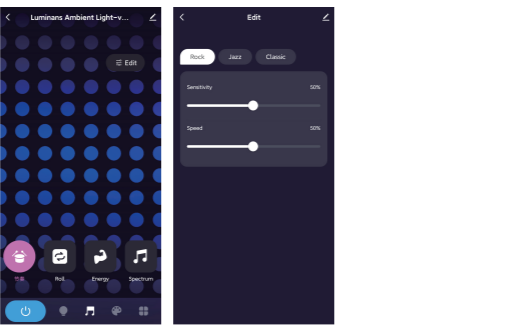

In the app you can create custom scenes (the custom scenes will be displayed in the scene interface after setting).

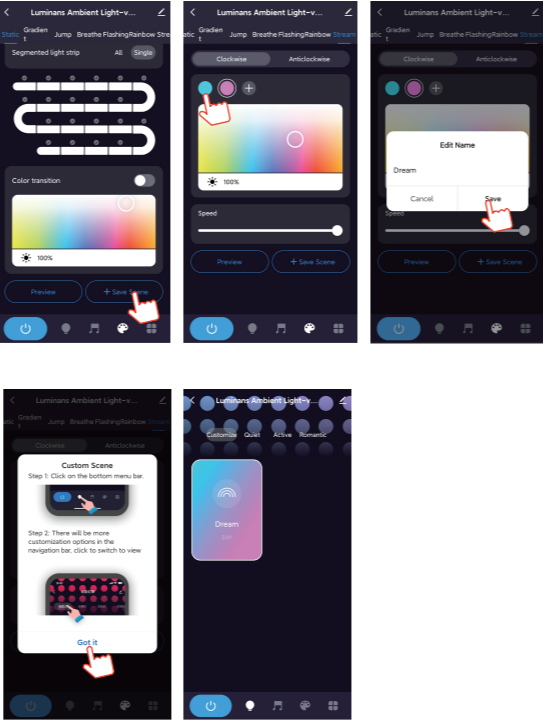

Third part control in the Tuya Smart App:

Find more services in the "Me" menu and find "More service", There you will find the access service from the third part (Alexa / Google Assistant etc). Choose the service you need. Connect to third part service device according to the instructions for use.

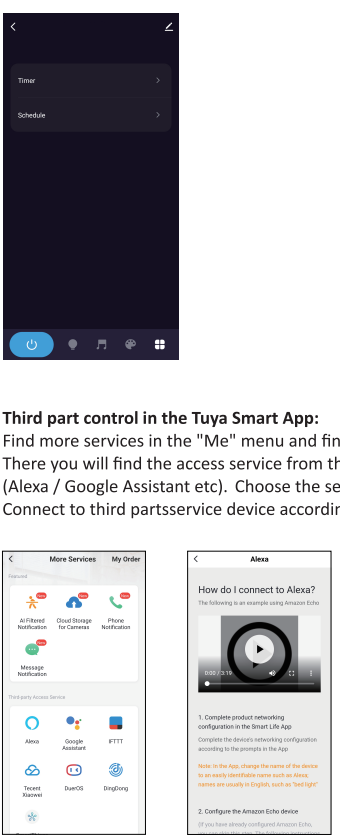

How to create / close device groups?

Please do the following:

- Press a device in the list to open the control panel.
- Press the button in the upper right corner to go to device edit page.
- Press Create Group. In "Select device" all devices are displayed which has been added to the account and has the same model as the device.
- On the device group page, click the button in the upper right corner to enter the settings page. Then click the "Reject group" button at the bottom of the page to reject this device group.
- If you want to handle different types of devices, or devices like does not support groups, you can add these devices to one "Tap-To-Run / Automation"
- If the creation of the group fails, click to see the solution.

Is it not possible to create a device group? Check the following:

- Click on the upper right corner of the device to enter the interface, and check if you can see the "Create group" function.
- If you can see it, click on it and create a group.
- If you do not see "Create group", it means that the device does not support group settings (not all types of equipment support group functions).

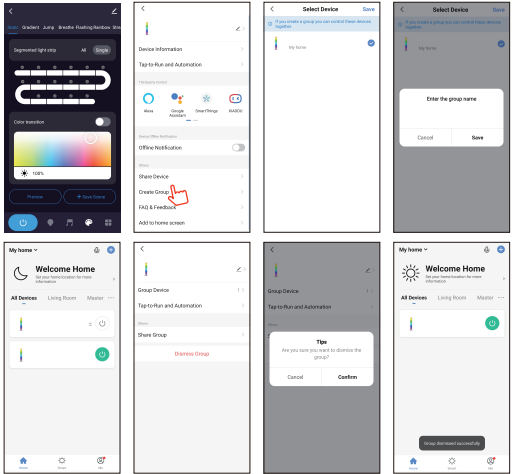

IR Music remote control manual

Product introduction:
IR remote control with 19 buttons for different color modes, For example running water and music modes etc.

Parameters:
Power supply: 3V button cell
Control distance: 5-8 meters free white fish

Instructions for the remote control:
Remove the PVC insulation sheet from the end of the remote control before use. Set the App Internet connection as a priority when the light is blinking.



Functions	Action	Buttons
ON / OFF	Short press	
Music mode pause / beat	Short press	
Speed / sensitivity	Short press	
Dynamic position change	Short press	
Music mode	Short press	
Automatic mode	Short press	
Brightness +/-	Short press	
Static color change	Short press	
W R G B	Short press	