

3-Segment electrical height adjustable desk frame

- ✓ 2 Motors / 3 segments
- ✓ Handset with LED
- ✓ 3 memory keys
- ✓ Anti collision function

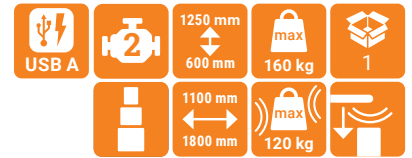

5 years warranty



## Details

### Frame

Anti-Collision	
Dynamic load:	120 kg max
Static load:	160 kg max
Speed:	38 mm/s
Stroke:	600 – 1250 mm
Frame width:	1100 – 1800 mm
Table-top size min.:	600 x 1100 mm
Table-top size max.:	1000 x 2200 mm

### Electrical Components / Handset

Input Voltage:	100 – 240 V
	built-in load limit switch
Duty cycle:	10 % max. 2 min on, 18 min off
Low energy consumption	automatic power off
Display:	digital
Memory keys:	3
USB charging function:	bottom of handset / 10 W



## Technical Drawings

Front

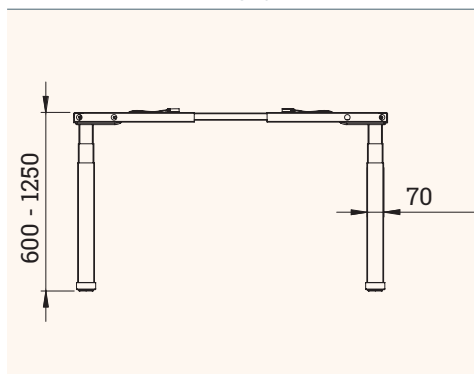

Side

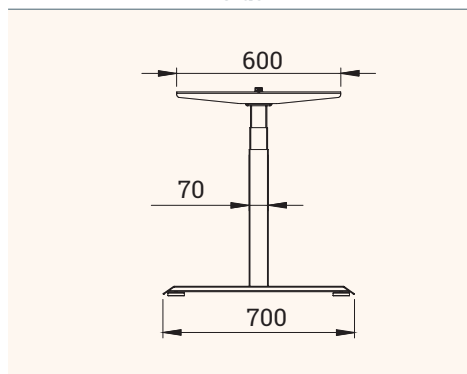

Top

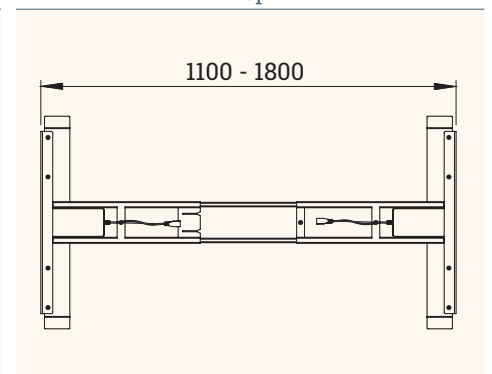

Article	Description	Colour	Item No.
E-MORE 2M3S TQD	Electrical height adjustable desk frame, 2 motors, 3 segments, square lifting columns	white aluminium, RAL 9006	301 123268
E-MORE 2M3S TQD	Electrical height adjustable desk frame, 2 motors, 3 segments, square lifting columns	traffic white, RAL 9016	301 123282
E-MORE 2M3S TQD	Electrical height adjustable desk frame, 2 motors, 3 segments, square lifting columns	jet black, RAL 9005	301 123275