



E86714, E6714
Akorn® Jr. Kamado Charcoal Grill

Welcome | Bienvenue | Bienvenido | Welkom! Willkommen | Benvenuti | Välkommen

Assembly Images are shown first. Please read and follow all warnings and instructions before assembling and using the appliance.

Les images de montage sont montrées en premier. Veuillez lire et suivre tous les avertissements et toutes les instructions avant de monter et d'utiliser l'appareil.

Las imágenes de ensamblaje se muestran primero. Lea y siga todas las advertencias e instrucciones antes de ensamblar y usar el artefacto.

De eerste pagina's zijn afbeeldingen van de montage. Lees en volg alle waarschuwingen en instructies, voordat u het apparaat monteert en gebruikt.

Die Montagebilder werden zuerst angezeigt. Bitte lesen und befolgen Sie alle Warnungen und Anweisungen, bevor Sie das Gerät montieren und verwenden.

Immagini del montaggio all'inizio. Leggere e rispettare tutte le avvertenze e le istruzioni prima di montare e mettere in funzione l'apparecchio.

Monteringsbilder visas först. Läs och följ alla varningar och anvisningar innan du monterar och använder apparaten.

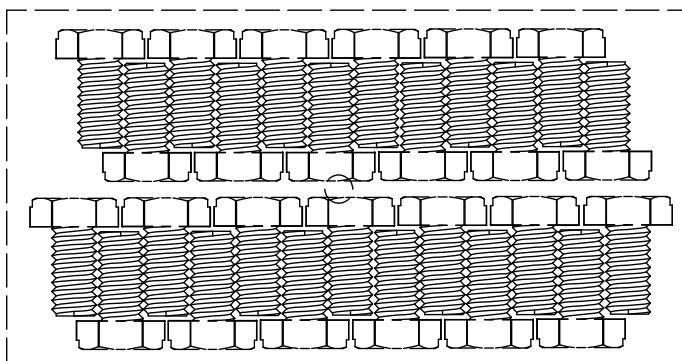
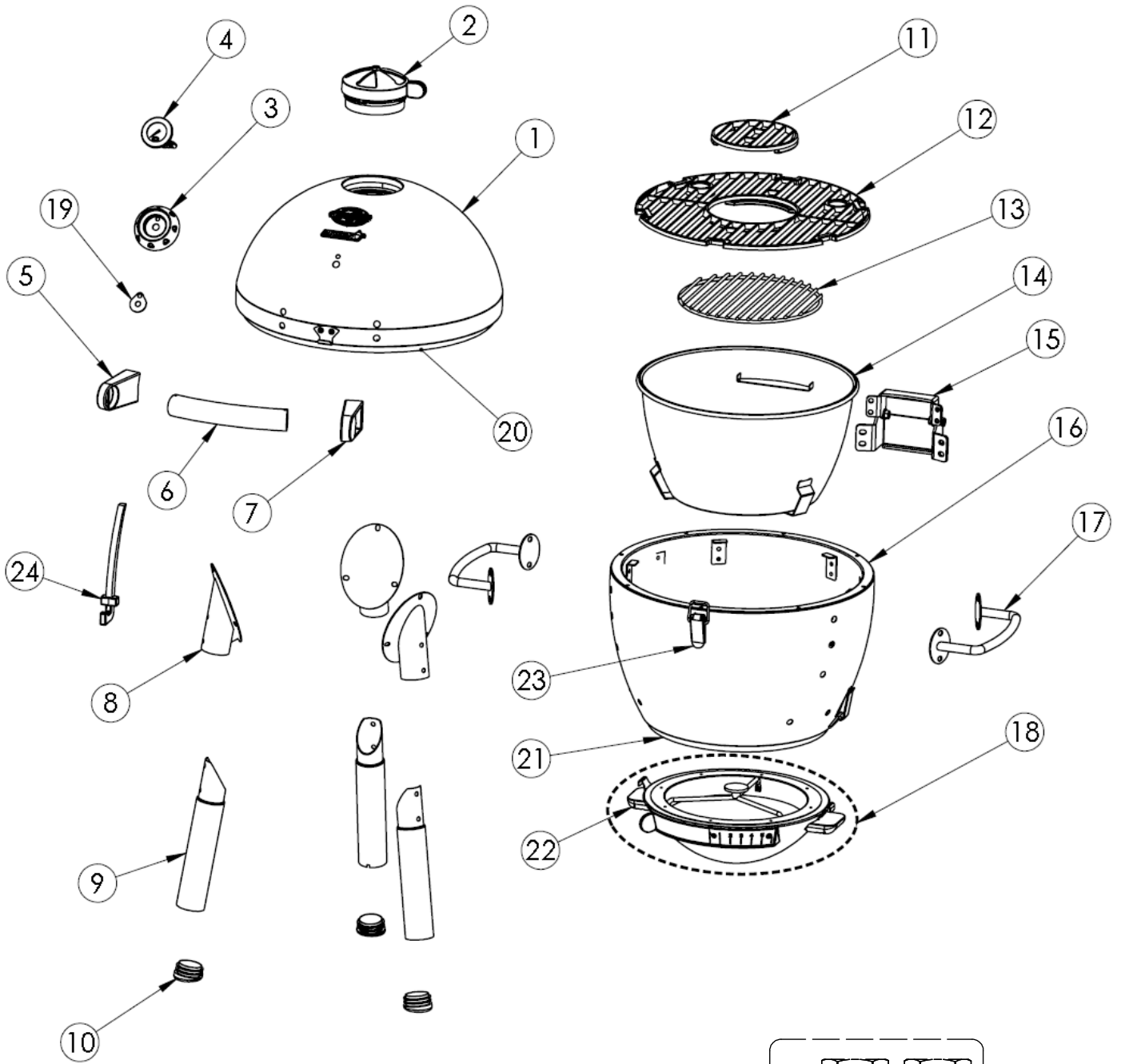

A
Qty:25

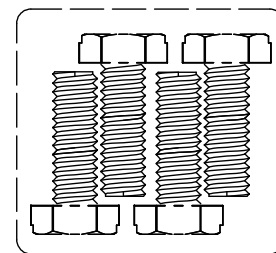

B
Qty:4

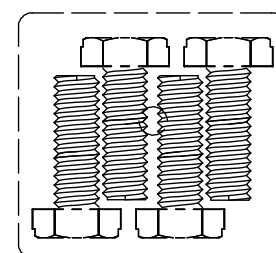

C
Qty:4

Parts List

Item	DESCRIPTION	QTY	Item	DESCRIPTION	QTY
1	Lid	1	13	Charcoal Grate	1
2	Top Damper	1	14	Fire Bowl	1
3	Temperature Gauge Bezel	1	15	Hinge	1
4	Temperature Gauge	1	16	Grill Body	1
5	Left Handle Bracket	1	17	Side Handle	2
6	Handle	1	18	Ash Pan	1
7	Right Handle Bracket	1	19	Temperature Gauge Gasket	1
8	Leg Bracket	3	20	Lid Seal	1
9	Leg	3	21	Ash Pan Seal	1
10	Foot	3	22	Ash Pan Handle	2
11	Inner Cooking Grate	1	23	Latch	3
12	Outer Cooking Grate	1	24	Grate Lifter	1

BEFORE ASSEMBLY READ ALL INSTRUCTIONS CAREFULLY

- Assemble on a clean flat surface.
- Recommend assembling on cardboard to avoid residue on floors or scratches.
- Gloves recommended for assembly.
- Tools needed: Phillips head screwdriver or 7/16" nut driver.
- Approximate assembly time: 30 minutes
- Recommend two people assemble to increase ease and reduce assembly time.
- Actual product may differ from picture shown.
- It is possible that some assembly steps have been completed in the factory.
- Remove all printed labels before use.

DO NOT RETURN TO RETAILER!

For assembly assistance, missing or damaged parts, please contact Char Griller Customer Service.

Char Griller® Premier Specialty Brands, LLC, 5367 New Peachtree Road, Suite 150, Chamblee, GA 30341

Char Griller® Kamado Joe Europe, Lange Voorhout 86, 2514 EJ, Den Haag, Netherlands

Char Griller® Kamado Joe UK Limited, Cheyenne House West Street, Farnham GU9 7EQ

Australia & New Zealand: Please contact your retailer

www.chargriller.com/pages/customer-support

www.chargriller.com/pages/customer-support

www.chargriller.com/pages/customer-support

1



2

C X 4

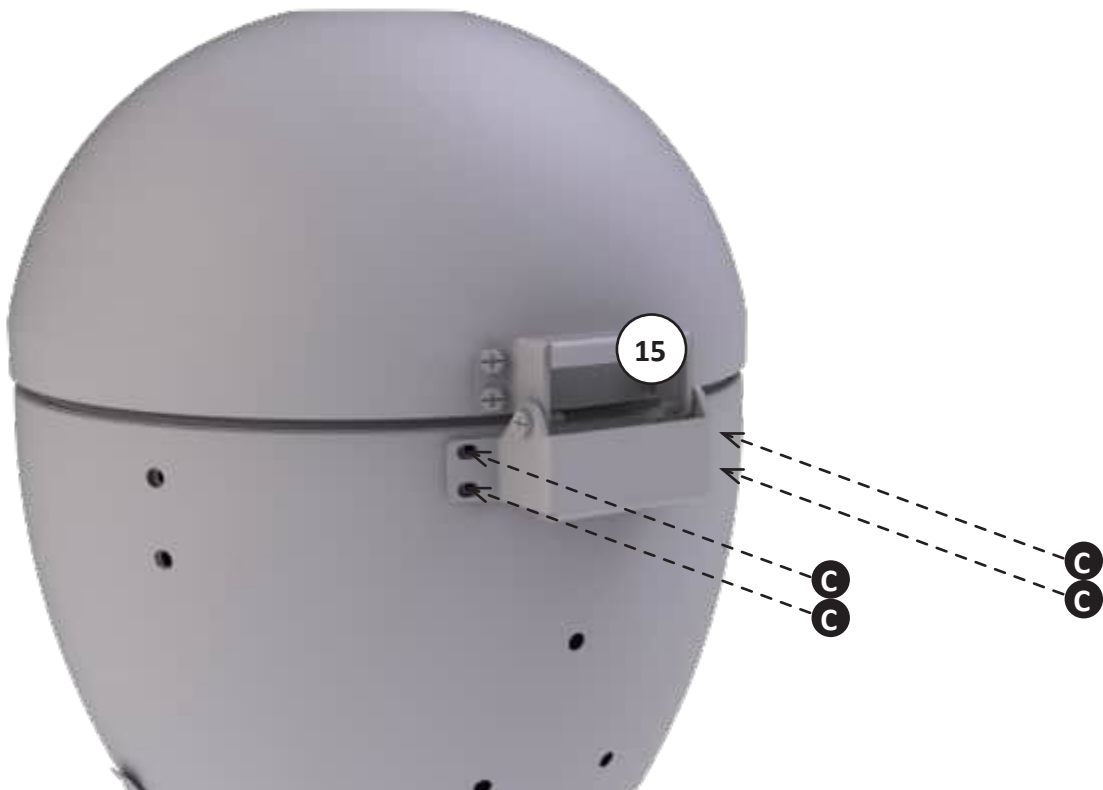

3

A X 8

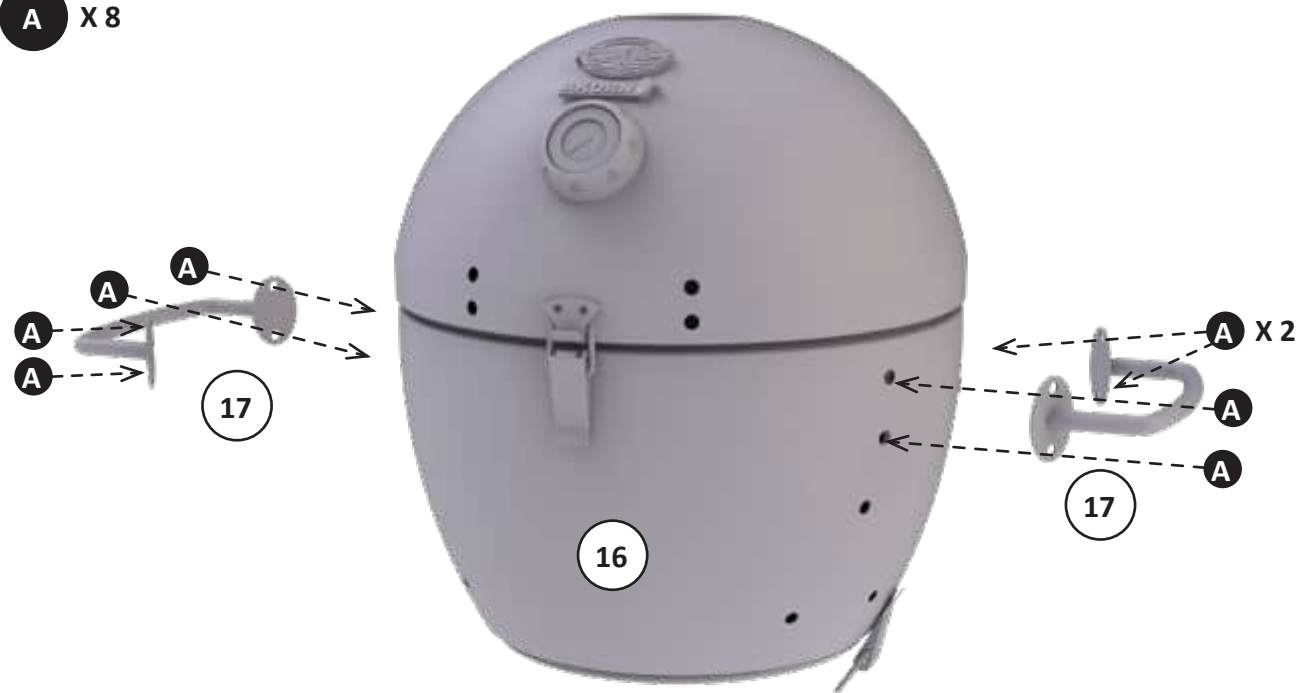

4

A X 6

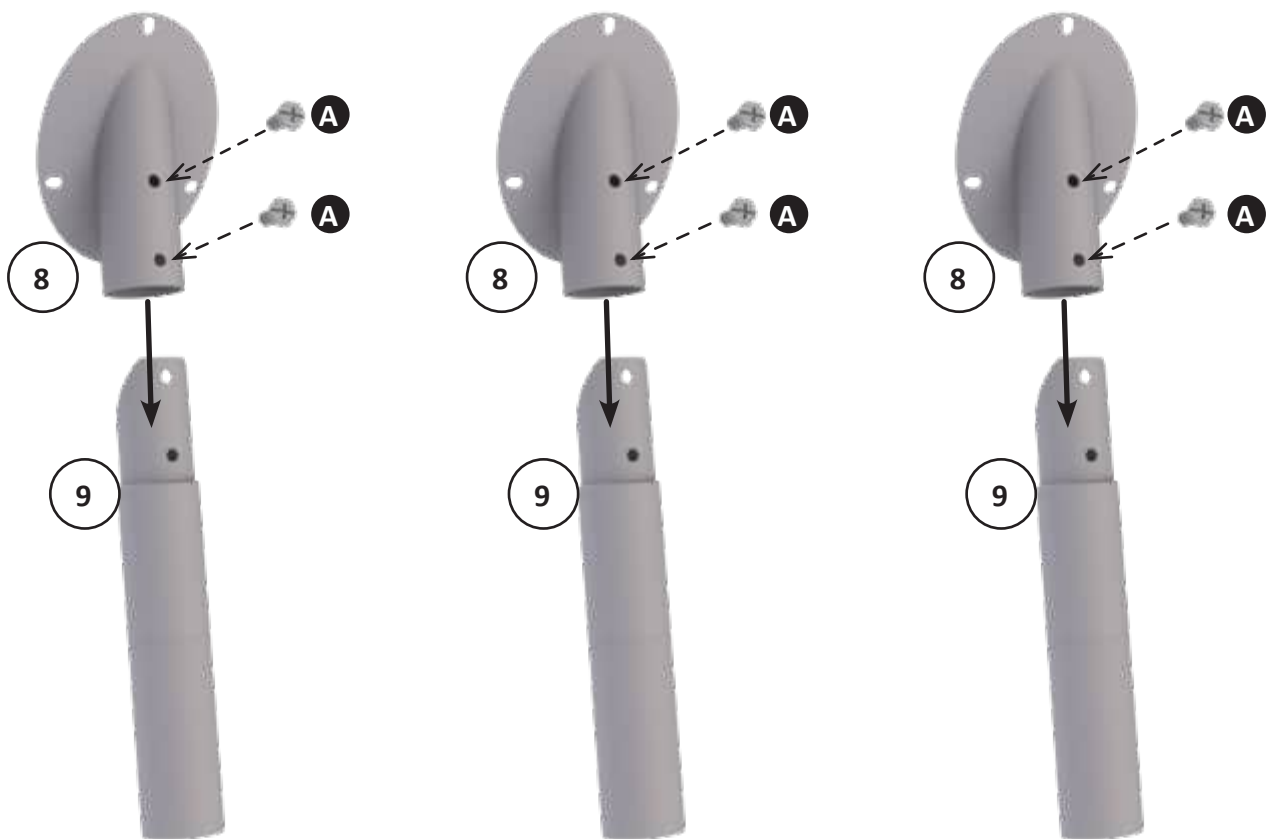

5

A X9

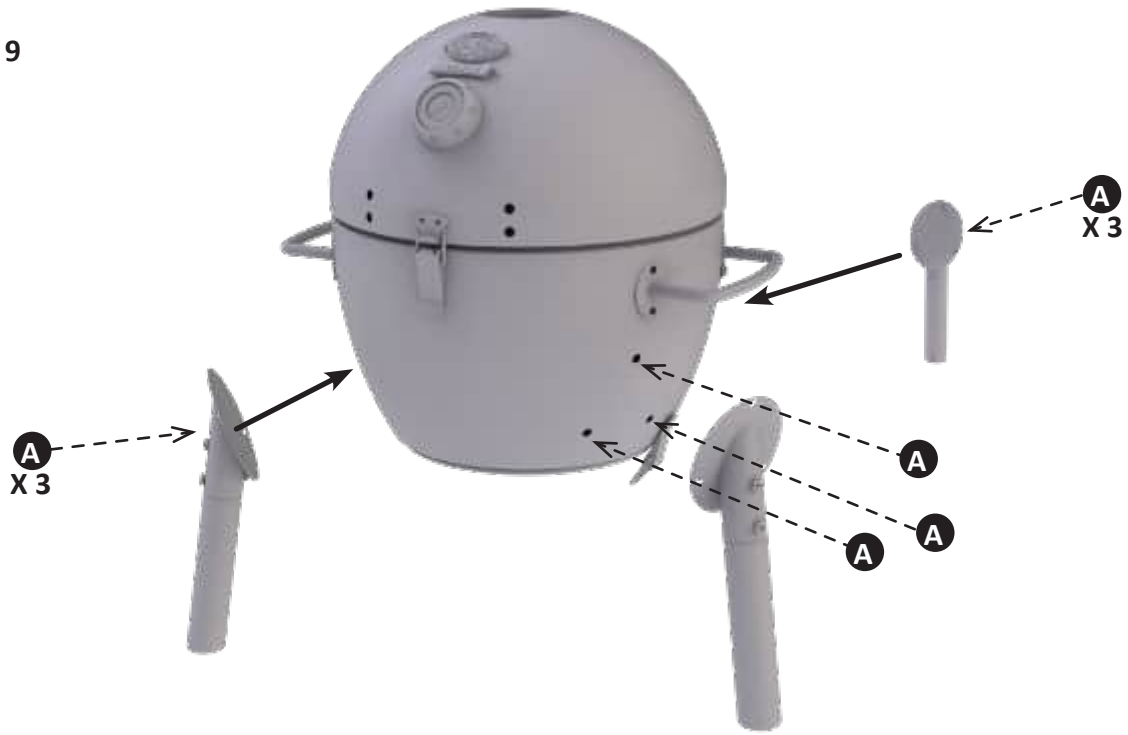

6

B X4

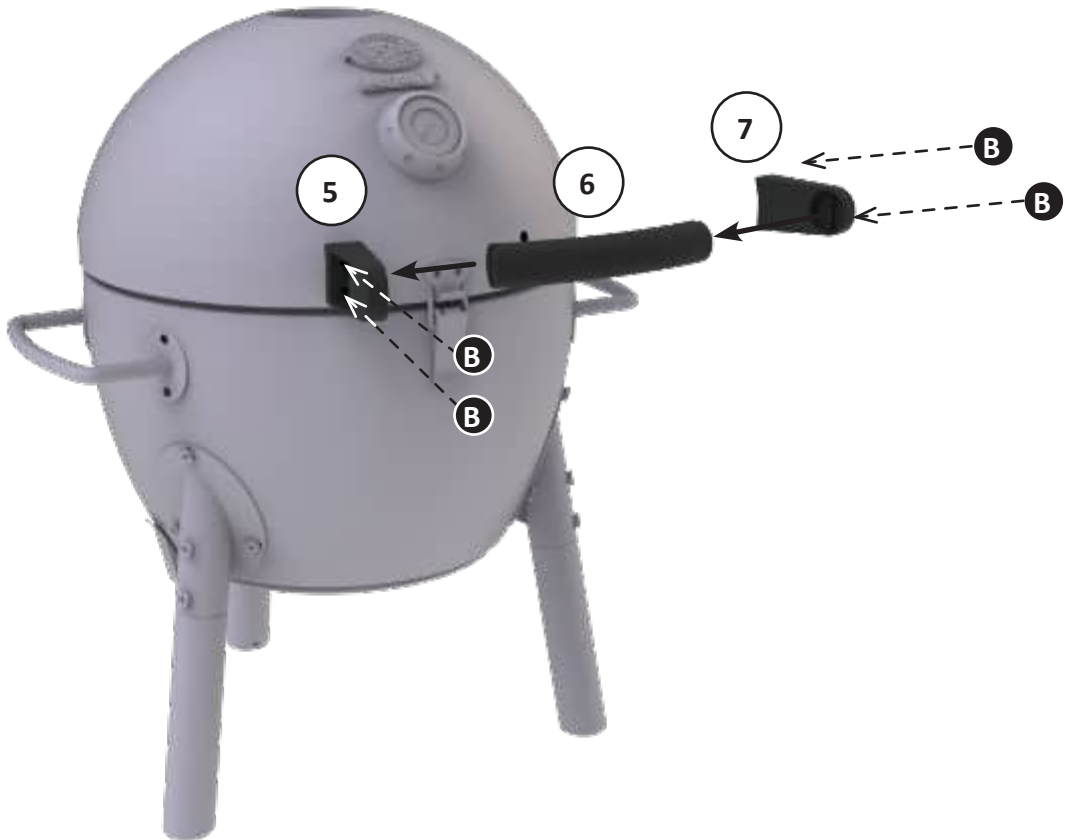

7

A X 2



8



18

9



FOR OUTDOOR USE ONLY. NOT FOR COMMERCIAL USE.



WARNING

- This manual contains important information necessary for the proper assembly and safe use of the appliance.
- Read and follow all warnings and instructions before assembling and using the appliance.
- Keep this manual for future reference.



CARBON MONOXIDE HAZARD

Failure to follow these instructions could result in fire, explosion or burn hazard which could cause property damage, personal injury, or death.

- Burning wood chips, wood chunks, wood pellets, charcoal and propane gives off carbon monoxide, which has no odor and can cause death.
- DO NOT burn wood chips, wood chunks, wood pellets, charcoal or propane inside homes, vehicles, tents, garages or any enclosed areas.
- Do not use the barbecue in a confined and/or habitable space e.g. houses, tents, caravans, motor homes, boats. Danger of carbon monoxide poisoning fatality.
- USE ONLY OUTDOORS where it is well ventilated.
- **FOLLOW THESE GUIDELINES TO PREVENT THIS COLORLESS, ODORLESS GAS FROM POISONING YOU, YOUR FAMILY OR OTHERS.**
 - Know the symptoms of carbon monoxide poisoning: headache, dizziness, weakness, nausea, vomiting, sleepiness, and confusion. Carbon monoxide reduces the blood's ability to carry oxygen. Low blood oxygen levels can result in loss of consciousness and death.
 - See a doctor if you or others develop cold or flu-like symptoms while cooking or in the vicinity of this appliance. Carbon monoxide poisoning, which can easily be mistaken for a cold or flu, is often detected too late.
 - Alcohol consumption and drug use increase the effects of carbon monoxide poisoning.
 - *Carbon monoxide is especially toxic to mother and child during pregnancy, infants, the elderly, smokers, and people with blood or circulatory system problems, such as anemia, or heart disease.*

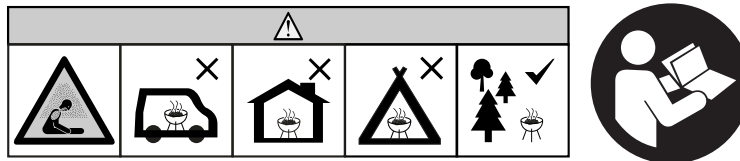

WARNINGS AND IMPORTANT SAFEGUARDS



READ ALL INSTRUCTIONS

- Do not leave grill unattended.
- Grill is for OUTDOOR HOUSEHOLD USE ONLY.
- Do not use indoors!
- Use charcoal for fuel only.
- Do not use grill in high winds!
- Close lid and dampers to help suffocate flame.
- Do not alter this grill in any manner.
- Do not exceed a temperature of 700°F (371°C) or more.
- Always use grill in accordance with all applicable local, state and federal fire codes.
- Potential damage to grill or harm to user may result from failure to follow warnings.
- Never use inside enclosed areas such as patios, garages, buildings, or tents.
- Never use inside or on recreational vehicles or boats.
- Do not use the barbecue in a confined and/or habitable space e.g. houses, tents, caravans, motor homes, boats. Danger of carbon monoxide poisoning fatality.
- Maintain a minimum distance of 3m (10ft) from overhead construction, walls, rails or other structures.
- Keep a minimum 3m (10ft) clearance of all combustible materials such as wood, dry plants, grass, brush, paper.
- Never operate grill under overhead construction such as roof coverings, carports, awnings, or overhangs. (SEE STRUCTURAL PROXIMITY REQUIREMENTS).
- Keep grill clear and free from combustible materials such as gasoline and other flammable vapors and liquids.
- Use grill on a level, non-combustible, stable surface such as dirt, concrete, brick, or rock. An asphalt surface (blacktop) may not be acceptable for this purpose.
- Do not use grill on wooden or flammable surfaces.
- Grill MUST be on the ground. Do not place grill on tables or counters. Do NOT move grill across uneven surfaces.



WARNINGS AND IMPORTANT SAFEGUARDS



- Grill should only be rolled on smooth surface.
- Grill should never be rolled up/down stairs or uneven surface.
- Never use grill as a heater (READ CARBON MONOXIDE HAZARD).
- Never use grill for anything other than its intended use. This grill is NOT for commercial use.
- Keep a fire extinguisher accessible at all times while operating grill.
- When cooking with oil or grease, have a type BC or ABC fire extinguisher readily available.
- In the event of an oil or grease fire do not attempt to extinguish with water. Immediately call the fire department. A type BC or ABC fire extinguisher may, in some circumstances, contain the fire.
- Before each use check all nuts, screws, and bolts to make sure they are tight and secure.
- Use of alcohol, prescription, or non-prescription drugs may impair user's ability to properly assemble or safely operate grill.
- Keep children and pets away from grill at all times. Do NOT allow children to use grill. Close supervision is necessary when children or pets are in the area where grill is being used.
- Do NOT allow anyone to conduct activities around grill during or following its use until it has cooled.
- DO NOT bump or impact the grill to prevent personal harm, damage to grill, or spillage/splashing of hot cooking liquid.
- Extreme caution must be used when moving an appliance containing hot oil or other hot liquids.
- Never move grill when in use. Allow grill to cool completely (45°C (below 115°F)) before moving or storing.
- The grill is HOT while in use and will remain HOT for a period of time afterwards and during cooling process. Use CAUTION. Wear protective gloves/mitts.
- Do not touch HOT surfaces. Use handles or knobs.
- Never use glass, plastic, or ceramic cookware in grill. Never place empty cookware in grill while in use.
- Accessory attachments not supplied by Char-Griller® are not recommended and may cause injury.
- Do not store grill with hot ashes or charcoal inside grill. Store only when fire is completely out and all surfaces are cold.
- Be careful when removing food from grill. All surfaces are HOT and may cause burns. Use protective gloves/mitts or long, sturdy, cooking tools for protection from hot surfaces or splatter from cooking liquids.
- Grill is hot during use. Keep face and body away from door(s) and vents. Steam and hot air are expelled during use.
- DO NOT obstruct flow of combustion and ventilation.
- Do not cover cooking racks with metal foil. This will trap heat and may cause damage to the grill.
- Never leave HOT coals or ashes unattended.
- Do not remove ash can while ashes and charcoal are HOT.
- Make sure to empty grease can after every use once completely cooled.
- Grill has an open flame. Keep hands, hair, and face away from flame. Do NOT lean over grill when lighting. Loose hair and clothing may catch fire.
- Use protective gloves when handling this grill or working with fire. Use protective gloves or long, sturdy fireplace tools when adding wood or charcoal.
- Air dampers are HOT while the grill is in use and during cooling; wear protective gloves when adjusting.
- Handles can be HOT while the grill is in use and during cooling; use extreme caution, if you touch the any handles, wear protective gloves
- Do not cook before the charcoal has a coating of ash.
- The barbecue should be heated up and the fuel should be kept red hot for at least 30mins prior to the first cook.
- Never use charcoal lighting fluid, gasoline, alcohol or other highly volatile fluids to ignite charcoal. These fluids can explode and cause injury or death.
- Never overfill charcoal grate. This can cause serious injury as well as damage to the grill.
- Never use more than the recommended amount of charcoal (see below).
- WARNING! This barbecue will become very hot, do not move it during operation.
- WARNING! Keep children and pets away.
- WARNING! Do not use spirit or petrol for lighting or re-lighting!
- WARNING! Do not use spirit or petrol for lighting or re-lighting! Use only firelighters complying to EN 1860-3!
- Never add additional lighter fluid once charcoal has ignited. Follow directions on lighter fluid container.
- Dispose of cold ashes by placing them in aluminum foil, soaking with water, and discarding in a non-combustible container.
- Keep lid open during the lighting process. Do not close the lid until the flames have burned down. Failure to follow this instruction may result in damage to painted surfaces due to excessive heat.

DO NOT EXCEED A TOTAL OF 1 LB / 0.45 KGS OF CHARCOAL FOR MAIN FIREBOX



STRUCTURAL PROXIMITY REQUIREMENTS



Maintain a minimum distance of 10 ft (3 m) from rear, sides and top of grill to all overhead construction, walls, rails or other combustible construction materials.

Maintain a minimum distance of 10 ft (3 m) from all combustible and flammable materials such as, wood, plants, grass, brush, paper, gasoline, or canvas.

This clearance provides adequate space for proper combustion, air circulation and venting. Grill should not be used on combustible materials like wood decks or other combustible materials.

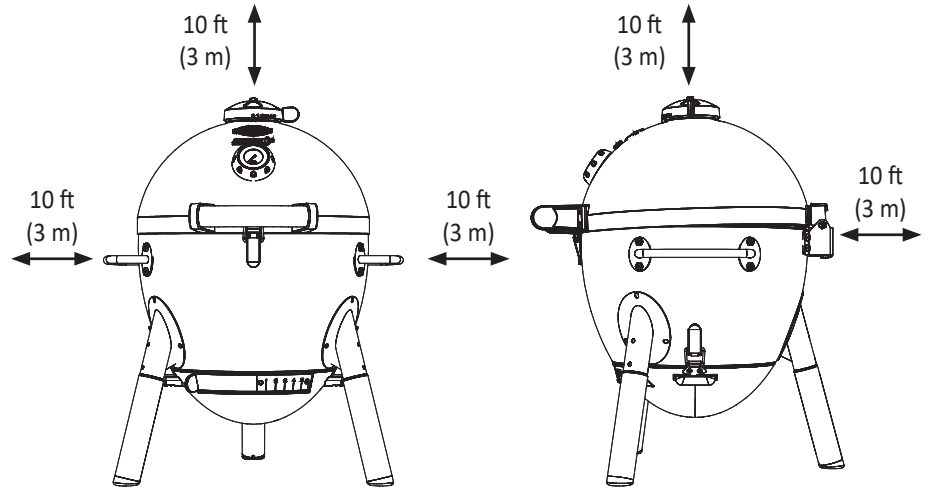

SAVE THESE INSTRUCTIONS

This product does not come with charcoal or wood chunks.

Operating Instructions

SETTING UP

Set grill up on solid, flat surface with adequate wind shelter.
Do not move grill while hot, and do not leave unattended during operation.

This appliance is designed for use outdoors, away from any flammable materials. It is important that there are no overhead obstructions and that there is a minimum distance of 10 feet (3 m) from the side or rear of the appliance. It is important that the ventilation openings of the appliance are not obstructed. The barbecue must be used on a level, stable surface. The appliance should be protected from direct drafts and positioned or protected against direct penetration by any trickling water (e.g. rain).

PRE-SEASONING

IMPORTANT! Pre-Seasoning will rid your grill of chemicals and oils left over by the manufacturing process, allowing them to burn off. PRE-SEASON GRILL PRIOR TO FIRST USE.

1. Lightly coat your cooking grates with food safe cooking oil.
2. Start grill by following the LIGHTING instructions. Build a medium sized fire.
 - Do not use more than 1 LB / 0.45 KGS of charcoal.
 - Always put charcoal on fire grate.
 - Never put charcoal directly into the bottom of the grill.
3. After coals ash over, spread out coals, replace cooking grates, close lid and heat to 400°F (204°C) for one hour.
4. **USE CAUTION!** Grates will be extremely HOT! Remove cooking grates from the grill with oven mitts, allow to cool, then re-coat grates with oil and return to grill at approximately 200°F (93°C) for two hours.
5. Frequent seasoning prevents rusting. If rusting occurs, clean with a steel brush, apply cooking oil or vegetable shortening and heat as indicated above.

NOTE: NEVER EXCEED A COOKING TEMPERATURE OF 700°F (371°C)

NOTE: After each use it is recommended to coat cooking grates in food safe cooking oil to help minimize any potential rust.

LIGHTING INSTRUCTIONS

Charcoal briquettes are safe to use, however, lump charcoal is recommend. Lump charcoal burns more efficiently than briquette and can provide a longer, more consistent burn during the cook.

DO NOT EXCEED A TOTAL OF 1 LB / 0.45 KGS OF CHARCOAL FOR MAIN FIREBOX

LIGHTING PROCESS

1. Create a pyramid of charcoal in the center of the fire grate.
2. Light coals in several places. Fire starters are recommended for this step.
3. Leave lid open until coals are ignited and smoke burns white.
4. After coals are ignited, close the lid and start regulating the dome temperature by adjusting the dampers.

NOTE:

- Always follow the charcoal manufacturer's instructions and warnings.
- Do not use lighter fluid, gasoline, kerosene, alcohol or other accelerant for lighting charcoal.
- If necessary, **USE EXTREME CAUTION** and use tongs or a long handled tool to move coals.
- Always wear heat resistant gloves when handling grill grates, charcoal grate, or adjusting coals.

Operating Instructions

MAINTAINING TEMPERATURE

In order to control the temperature of your grill, you need to control the amount of air flow to the fire. By opening and closing the top and bottom damper, you can adjust the temperature of your grill.

- MORE AIR = MORE HEAT
- LESS AIR = LESS HEAT

The amount of charcoal used when grilling can also greatly impact your ability to control temperature. The more charcoal that ignites, the hotter the grill can be.

- MORE CHARCOAL = MORE HEAT
- LESS CHARCOAL = LESS HEAT

NOTE:

- Due to the efficiency of the design of the Akorn, it is challenging to LOWER the temperature while cooking. USE CAUTION, do not over exceed your desired cooking temperature.

COOKING STYLES

LOW and SLOW (*Smoking*)

1. Use a small amount of charcoal to start your fire (approximately 0.5 LBS / 0.25 KGS)
2. Follow lighting instructions, however, ignite your charcoal pile from the TOP of the pyramid.
3. After coals ignite, shut the lid and adjust the dampers to be 1/4 or less of the way open. Adjust more as needed.

MEDIUM / HIGH HEAT (*Grilling and Searing*)

1. Use a medium amount of charcoal to start your fire (approximately 1 LB / 0.45 KGS)
2. Follow lighting instructions, however, ignite your charcoal pile from the BOTTOM of the pyramid.
3. After coals ignite, shut the lid and adjust the dampers to be 3/4 or more of the way open. Adjust more as needed.

INDIRECT HEAT (*Smoking*)

WHY INDIRECT COOKING?

This cooking method is ideal for roasting larger cuts of meat. It will allow you to achieve a low and slow cook while trapping moisture in the grill. This method is ideal for longer cooks.

1. To achieve an indirect heat, it is recommended to deflect the coals with the Char-Griller Smokin' Stone or heat deflector. **Smokin' Stone sold separately.**
2. Place the Smokin' Stone or heat deflector UNDER the cooking grate and above the coals.
3. It is recommended to utilize a drip pan or water bowl with this cooking method as well to help moisture stay in the cook chamber.

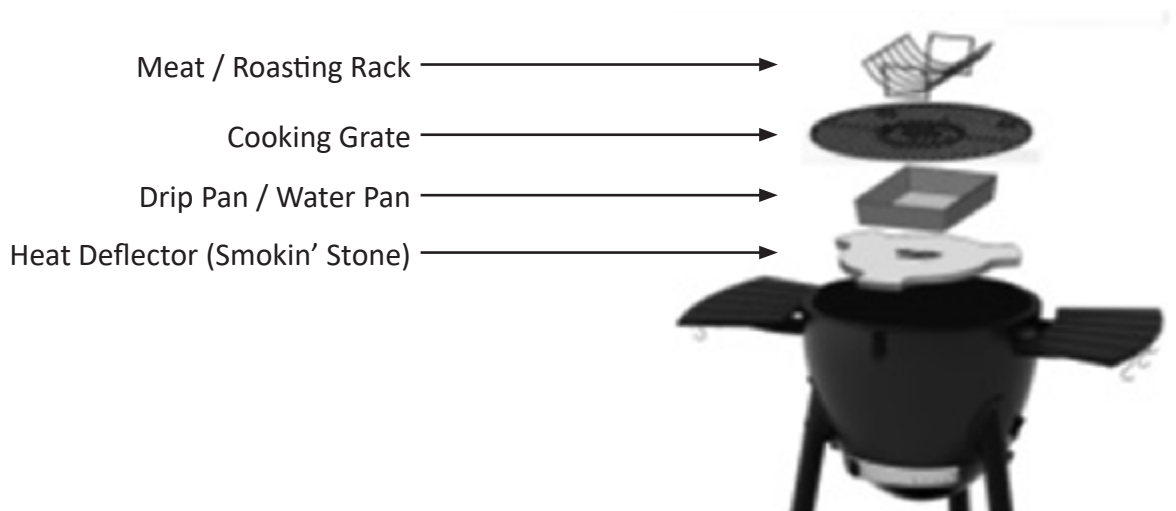

Operating Instructions

RELOAD

If additional charcoal should be needed, use extreme caution. Cooking grate will be VERY hot. Remove the center of your cooking grate to add charcoal at anytime during the cook. Use the grate lifter or a tool to remove the center of the cooking grate. Only add a small amount of charcoal at a time. NOTE - adding new charcoal to the fire may induce a large amount of smoke.



SHUT DOWN

When finished cooking, clean your cooking grates with a cooking grate scraper then lightly coat with cooking oil.

Allow the temperature to drop to below 350F (177C). Once the temperature is below 350F (177C) close all lids and dampers. This will help extinguish the charcoal. Allow time for the grill to cool completely before moving on to the cleaning and care section.

GRATE LIFTER

Use your grate lifter to handle your cooking grates. CAUTION! Cooking grates can be HOT! Use the grill gripper to re-position the cooking grates throughout your cook.

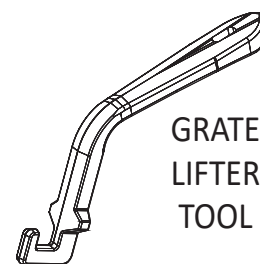

Cleaning and Care

REGULAR MAINTENANCE

In order to keep your grill in the best shape regular cleaning and maintenance is required. The best way to protect your grill from the elements is with a grill cover.

- ALWAYS MAKE SURE UNIT IS COOL TO THE TOUCH BEFORE CLEANING AND STORING.
- Inspect hardware and assembled parts on a regular basis to ensure grill is in safe working condition.
- Knock all ashes off of the fire grate. IF there is charcoal remaining on the fire grate, you can utilize for the next cook.
- Always empty the ash tray after each use once ashes have completely cooled. Empty the ashes into a metal container and cover with water to ensure there are no lit coals.
- Unclip the ash tray from the bottom of the grill and slide out towards the front.
- Clean grill and cooking grids with mild cleaning agents. Wipe outside of grill with a damp rag. DO NOT use oven cleaner.
- Always cover and store cold grill in a protected area.
- Indoor storage of grill is permissible only if the charcoal has burned to a complete ash and is cold.
- Remember to remove cold ashes before storing.
- Your grill is made of steel and some rust may appear over time. If rust occurs clean the area with fine sandpaper or steel wool, then cover with heat resistant paint.
- NEVER USE PAINT ON INSIDE SURFACES OF GRILL.
- Frequent seasoning prevents rusting. If rusting occurs, clean with a steel brush, apply cooking oil or vegetable shortening and heat as indicated in the pre-seasoning steps.

WARRANTY INFORMATION

A COPY OF THE DATED PROOF OF PURCHASE (RECEIPT) IS REQUIRED WHEN REGISTERING OR SUBMITTING A WARRANTY CLAIM. PLEASE RETAIN A COPY OF THE RECEIPT FOR YOUR RECORDS.

Char-Griller® will replace any defective part of its grillers/smokers, under warranty, as outlined below.

Charcoal / Pellet / Kamado Grills	
Grill - Hood AND Bottom (excludes removable Ash Pan)	5 years from date of purchase for rust through / burn through
Ash Pan AND Defective Parts	1 year from date of purchase
Gas Grills	
Grill Hood (TOP half) AND Main Burner Tubes (excludes Side Burner)	5 years from date of purchase for rust through / burn through
Grill Body (BOTTOM half) AND Side Burner AND Defective Parts	1 year from date of purchase
Dual Fuel Grills (Gas & Charcoal)	
Charcoal Grill - Hood AND Bottom AND Gas Grill - Hood (TOP half) AND Main Burner Tubes (excludes Ash Pan and Side Burner)	5 years from date of purchase for rust through / burn through
Ash Pan AND Defective Parts AND Gas Grill Body (BOTTOM half) AND Side Burner	1 year from date of purchase
Griddles	
All defective parts	1 year from date of purchase
MISC	
Parts, Accessories, and Grill Covers	1 year from date of purchase (seam tears only for covers)

SURFACE RUST IS NOT CONSIDERED A MANUFACTURING OR MATERIALS DEFECT

Char-Griller® grills are made of steel and if exposed to the elements rust will occur naturally. Please refer to the manual to review how to care for your grill properly.

Surface issues such as scratches, dents, corrosion or discoloring by heat, abrasive and chemical clearers, surface rust or the discoloration of steel surfaces are NOT covered under these warranties.

Warranties are for the replacement of defective parts only. Char-Griller® is not responsible for damage resulting from accident, alteration, misuse, abuse, hostile environments, improper installation, and installation not in accordance with local codes of service of unit.

AUSTRALIA AND NEW ZEALAND RESIDENTS ONLY: Our goods come with guarantees that cannot be excluded under the Australian or New Zealand Consumer Law. You are entitled to a replacement or refund for a major failure and compensation for any other reasonably foreseeable loss or damage. You are also entitled to have the goods repaired or replaced if the goods fail to be of acceptable quality and the failure does not amount to a major failure.

EUROPEAN RESIDENTS ONLY: Char-Griller® warrants all of its products to be free from defects in material and workmanship under proper assembly, normal use and recommended care for 2 years from the date of original retail purchase.

Excluded Under ALL Warranties

Paint; Surface Rust; Heat Damage; Incorrect Parts ordered by customer, including shipping; Worn Parts; Missing or damaged parts not reported within two (2) months of purchase date; Defective parts not reported within one (1) year of purchase date; Fading grill cover.

*NOTE: For warranty claims, photos and prepaid return of the item in question may be required. Misuse, abuse or commercial use nullifies all warranties.

PLEASE READ THIS INFORMATION IN DETAIL AND IF YOU HAVE ANY QUESTIONS CONTACT CUSTOMER SERVICE AT:

DO NOT RETURN TO RETAILER!

For assembly assistance, missing or damaged parts, please contact Char Griller Customer Service.

Char Griller® Premier Specialty Brands, LLC, 5367 New Peachtree Road, Suite 150, Chamblee, GA 30341

www.chargriller.com/pages/customer-support

Char Griller® Kamado Joe Europe, Lange Voorhout 86, 2514 EJ, Den Haag, Netherlands

www.chargriller.com/pages/customer-support

Char Griller® Kamado Joe UK Limited, Cheyenne House West Street, Farnham GU9 7EQ

www.chargriller.com/pages/customer-support

Australia & New Zealand: Please contact your retailer

